



Consolidated Version - for convenience only  
– for a true copy contact the District Office.

# **SUBDIVISION OR DEVELOPMENT OF LAND BYLAW NO. 154, 2001**

Consolidated to December 6, 2021

Consolidated for convenience only to include Bylaws:  
169, 334, 371, 393, 398 and 435

CONSOLIDATED

**DISTRICT OF HIGHLANDS  
SUBDIVISION OR DEVELOPMENT  
OF LAND BYLAW, 2001**

Users of this bylaw are advised that they should also be knowledgeable of the requirements of the:

1. Land Title Act
2. Local Government Act
3. Strata Property Act
4. Real Estate Act
5. Forest Land Reserve Act
6. Land Survey Act
7. Public Health Act
8. Drinking Water Protection Act
9. Waste Management Act
10. District of Highlands Zoning Bylaws
11. District of Highlands Official Community Plan Bylaw
12. District of Highlands Tree Management Bylaw
13. District of Highlands Blasting Bylaw
14. Capital Regional District Deposit of Soil Bylaw
15. Capital Regional District Soil Removal Bylaw

*\*7&8 added under Bylaw No. 371*

In regard to subdivisions and the development of lands in Highlands

# EXPLANATORY NOTES DISTRICT OF HIGHLANDS SUBDIVISION OR DEVELOPMENT OF LAND BYLAW, 2001

---

Users of this Bylaw are advised that it does not contain a complete code of all the regulations governing subdivision in the District of Highlands. The primary purpose of this Bylaw is to establish standards for works and services that must be installed to serve subdivisions approved under the *Land Title Act* and the *Bare Land Strata Regulations* and building projects which are required to be serviced in accordance with Council Policy Resolution No. \_\_\_\_\_ and No. \_\_\_\_\_.

This Bylaw is enacted under the *Local Government Act*. At the time of adoption of the Bylaw, other enactments regulating subdivision included:

1. The *Local Government Act*, governing excess or extended services and latecomer payments, provision of park land, changes to bylaws following an application for subdivision, highway provision and widening, and relative residence subdivisions.
2. The *Land Title Act*, governing subdivision plan requirements, access requirements, appointment and powers of the approving officer, subdivision of land subject to flooding, review of subdivision plans, appeals and registration.
3. The *Strata Property Act*, which regulates strata subdivision, including building strata plans, conversion of existing buildings, bare land strata plans and phasing of strata plans. The *Bare Land Strata Regulations* establish servicing requirements, which include compliance with this Bylaw.
4. Numerous other enactments govern special topics relating to subdivision, particular types of subdivision, or subdivision in special areas. These include, among others, the *Land Title Act* (air space parcels and interior boundary cancellations), the *Real Estate Development Marketing Act*, (prospectus requirements), and the *Land Survey Act*.

1.	Citation and Repeal.....	1
2.	Schedules.....	1
3.	Definitions.....	1
4.	Application.....	4
5.	Severability.....	4
6.	Application Procedures.....	4
7.	Fees and Payments.....	4
8.	Approving Officer- Administration.....	5
9.	Preliminary Layout Assessment For Subdivision.....	6
10.	Design and Installation of Works and Services.....	6
11.	Subdivision Approval.....	7
12.	Security for Servicing.....	7
13.	Bylaw Compliance.....	8
14.	Incorporation of Document by Reference.....	8

## DISTRICT OF HIGHLANDS

### BYLAW NO. 154

#### A BYLAW FOR REGULATING THE SUBDIVISION OR DEVELOPMENT OF LAND

---

The Council of the District of Highlands, in open meeting assembled hereby enacts as follows:

#### 1.0 CITATION AND REPEAL

- 1.1 This Bylaw may be cited as "Subdivision or Development of Land Bylaw No. 154, 2001."
- 1.2 Capital Regional District Bylaw No. 986, cited as "Langford Subdivision Bylaw, 1982", and all amendments thereto, are hereby repealed.

#### 2.0 SCHEDULES

Schedules 'A', 'B', 'C', 'D', 'E', and 'F' are attached to and form part of this Bylaw.

#### 3.0 DEFINITIONS

##### "APPLICANT"

means an owner of land who applies for approval to subdivide that land and includes an agent duly authorized in writing by the owner.

*\*added under Bylaw No. 371, 2016*

"AUTHORIZED PERSON" means a registered onsite wastewater practitioner or a professional pursuant to the BC Sewerage System Regulation

##### "COLLECTOR ROAD"

means a road designated as a collector road in the District of Highland's Official Community Plan as amended from time to time.

##### "CONSULTING ENGINEER"

means a professional engineer registered under the Engineers and Geoscientists Act who is retained by the owner to design and supervise the construction of works and services required by this Bylaw.

##### "CUL-DE-SAC ROAD"

means a road which terminates with a vehicular turning area.

**“DEVELOPMENT”**

means any improvement to residential, commercial, industrial or institutional lands, highways and rights-of-way requiring the installation of works and services.

**“DISTRICT”**

means the District of Highlands.

**"FRONTAGE"**

means the common boundary line between a parcel and the road or bare land strata road from which the parcel obtains its principal vehicular access.

**"HIGHWAY"**

includes a public street, lane, bridge, viaduct and any other way open to public use, but does not include a private right-of-way on private property.

*\*Added under Bylaw 334, 2012*

**“INDUSTRIAL ROAD”**

means a highway providing access to a commercial or industrial zoned property.

**"LAYOUT"**

means a sketch or plan drawn to scale, showing dimensions and areas of proposed parcels, locations of existing buildings, proposed highways, and the locations of all existing and proposed works and services and rights-of-way on and adjacent to the land proposed to be subdivided.

**"LOCAL ROAD"**

means a highway designed or intended to provide direct access to adjoining properties and intended to move volumes of traffic less than an average annual daily traffic of 1,500 of all types of vehicles.

**"MUNICIPAL UTILITY"**

means any system having facilities installed in a highway or right-of-way for the purpose of providing a service to property by the District including water distribution, sewage and drainage collection, and street lighting systems.

**"ON-SITE WORKS AND SERVICES"**

means works and services located within the boundaries of the land being subdivided or developed and not located within a dedicated highway.

**“OWNER”**

in respect of real property means the registered owner of an estate in fee simple, and includes:

- (a) the tenant for life under a registered life estate; or
- (b) the registered holder of the last registered agreement for sale.

"PARCEL"

means any lot, block, or other area in which land is held or into which land is subdivided but does not include a highway.

"PARCEL WIDTH"

means the horizontal distance between side lot lines measured at right angles to the lot depth and ten metres from the front lot line.

*\*amended under Bylaw No. 371, 2016*

"POTABLE WATER"

means water which is approved for drinking water purposes by the Medical Health Officer/Drinking Water Protection Officer in accordance with the *Drinking Water Protection Act* and *Drinking Water Protection Regulation*

"PRELIMINARY LAYOUT ASSESSMENT"

means written notification of a review of information presented to the Approving Officer prior to submission of a subdivision plan for final approval.

"PRIVATE UTILITY"

means any system having facilities installed in an easement, common property or right-of-way for the purpose of providing a service to property by a utility not owned by a local government, including water distribution, sewage and drainage collection, street lighting, electric power distribution, telephone, cable television, and gas distribution systems.

"ROAD"

means a highway that affords the principal means of vehicular access to abutting parcels.

"ROADWAY"

means the portion of a road that is improved, designed and used for vehicular traffic.

"SECURITY"

means a cash deposit, certified cheque or unconditional irrevocable letter of credit issued by a Canadian Chartered Bank or Credit Union, to ensure the completion of works and services required by this Bylaw.

"SERVICE LEVEL"

means the standard of services required for development or subdivisions.

"SUBDIVISION"

means the division of land into two or more parcels whether by plan, descriptive words, or otherwise, but excludes a strata plan which is not a bare land strata plan. It also includes an alteration of the lot lines of a parcel.

**“SUBDIVISION APPROVAL”**

means approval of the subdivision of land granted by the Approving Officer when all relevant requirements of this bylaw, the Land Title Act, the Local Government Act and any other relevant bylaws and legislation have been fulfilled.

**"SURVEYOR"**

means a land surveyor licensed and registered as a land surveyor in the Province of British Columbia.

**"WALKWAY"**

means a highway for the use of the walking public only, except that a walkway may be designed to afford emergency vehicle use.

**"WATER COURSE"**

means any natural or manmade drainage course or source of water, whether usually containing water or not, and includes any lake, river, stream, creek, spring, ravine, swamp or gulch.

*\*added under Bylaw 371, 2016*

**“WATER SUPPLY SYSTEM”**

means a water supply system providing water intended for domestic use to more than one single-family residence as defined in the Drinking Water Protection Act

**"WORKS AND SERVICES"**

means the roadways, onsite sewage disposal, drainage, water or sewer systems, sidewalks, boulevards, street lighting and underground wiring and all other works required by this Bylaw.

Unless otherwise defined herein any word or expression in this Bylaw shall have the meaning assigned to it in the Local Government Act or Interpretation Act, or in the Land Title Act if not defined in the Local Government Act or Interpretation Act.

**4.0 APPLICATION**

This Bylaw applies to all lands, buildings, and structures within the area incorporated as the District of Highlands.

**5.0 SEVERABILITY**

If any section, subsection, clause, sub-clause or phrase of this Bylaw is for any reason held to be invalid by the decision of any court of competent jurisdiction, such decision shall not affect the validity of the remaining portions of this Bylaw.

## 6.0 APPLICATION PROCEDURES

Every application for Preliminary Layout Assessment, Design Drawing Assessment, or Subdivision Approval shall be made by the registered owner or by his agent authorized in writing using the forms prescribed in Schedule 'D', Standard Forms and Certificates. The information required to be provided with the application must be so provided and the works required to be performed prior to the application submission must be so completed.

## 7.0 FEES AND PAYMENTS

*\*\*Amended under Bylaw No. 398, 2018*

- 7.1 At the time of initial application for Preliminary Layout Assessment a fee of \$3,000 plus \$200.00 for each parcel to be created in addition to the number of existing parcels is to be paid, provided that the application fee for a subdivision that does not increase the number of parcels is \$1,500 and no further fee is required under Section 7.3 in respect of that subdivision.

If the applicant wishes to submit a revised application within four weeks of the original submission the fee for considering the revised application will be \$500.00.

If the applicant wishes to submit a revised application after more than four weeks, but less than one year, from the date of the original submission, the fee for each revised submission shall be fifty percent (50%) of the original submission fee.

For a revised application submitted later than one year from the date of the original submission the applicant must pay the same fees as for a new application.

- 7.2 Any applicant submitting design drawings for assessment and wishing to construct works and services prior to the approval of the subdivision of the property shall pay a fee of \$500.00 for each parcel to be created in addition to the number of existing parcels. For a revised application of these design drawings based on a revised subdivision application the applicant shall pay a fee equal to fifty percent (50%) of the original fee calculated in this regard.

*\*\*Amended under Bylaw No. 398, 2018*

- 7.3 Upon submission of a subdivision plan to the Approving Officer by the property owner or the appointed agent wishing to apply for approval of a subdivision of the property, a fee of \$3,000.00 plus \$1,000.00 for each parcel to be created in addition to the number of existing parcels is to be paid. If the applicant has made payment of fees under Section 7.1 or 7.2 then, the above fee is reduced by the amount of fees already paid provided that a minimum fee of \$300.00 shall be paid for each parcel to be created in addition to the number of existing parcels.

7.4 Where an Applicant wishes to enter into a servicing agreement with the District, then a non-refundable administration fee of \$500.00 shall be paid at the time of the request.

*\*\*Section 7.5 deleted and 7.6 renumbered under Bylaw No. 398, 2018*

7.5 In addition to the above required fees, the applicant will be required to pay any costs for having an examination and/or a report made on any aspect of the subdivision or possible impact of the subdivision.

#### 8.0 APPROVING OFFICER - ADMINISTRATION

8.1 The Approving Officer shall refuse to approve the subdivision of any parcel of land unless all the relevant requirements of this bylaw, the Local Government Act, and the Land Title Act and other relevant statutes and bylaws have been complied with.

8.2 The Approving Officer or such other person as the Council may designate, may enter at all reasonable times upon the land for which an application has been made for the purpose of administering or enforcing this bylaw.

8.3 No person shall prevent or obstruct, or attempt to obstruct, any such official from the carrying out of his duties under this bylaw.

#### 9.0 PRELIMINARY LAYOUT ASSESSMENT FOR SUBDIVISION

9.1 The applicant may request a preliminary layout assessment of any proposed subdivision of any existing parcel before applying for subdivision approval.

9.2 Every application for Preliminary Layout Assessment shall be tendered in writing in the applicable form prescribed in Schedule 'D'. An application for preliminary layout assessment must be accompanied by the documentation indicated in Schedule 'D'.

#### 10.0 DESIGN AND INSTALLATION OF WORKS AND SERVICES

*\*\*Amended under Bylaw No. 435, 2021*

10.1 No parcel shall be subdivided unless the land is serviced in compliance with the standards set out in Schedules B and E, except where the subdivision creates no additional parcels, or any additional parcels created by the subdivision are intended only for park, highway, or public utility purposes.

10.2 The service levels for subdivision of lands within each zone of the Zoning Bylaw shall be in accordance with the service levels contained within Schedule A.

10.3 All on-site works and services in bare land strata subdivisions creating four or more strata lots shall be in accordance with the service levels contained in Schedule A and the specifications contained in Schedules B.

- 10.4 In bare land strata subdivisions creating fewer than four strata lots, all onsite works and services shall be in accordance with the service levels contained in Schedule E and the specifications contained in Schedule B.
- 10.5 The owner shall retain, at his expense, a consulting engineer who shall be responsible for the design, layout, approval of materials, field reviews of installation, communication with the contractor, information for and certification of as-constructed drawings for all services that are the responsibility of the owner.
- 10.6 All of the works and services for the subdivision are to be inspected and supervised during construction by the owner's consulting engineer for compliance with this bylaw. Resident inspection is required during construction and the consulting engineer, on a weekly basis, shall submit copies of his daily inspection reports to the District of Highlands.
- 10.7 A copy of the Engineer's Undertaking form as contained in Schedule D, is to be completed and submitted to the Approving Officer at the time of subdivision application submissions. Should there be any changes to the agreement, the Approving Officer shall be notified in writing 48 hours in advance of the changes occurring. A copy of the Certificate of Inspection form, as contained in Schedule D, is to be completed and submitted to the Approving Officer as part of the as-constructed submissions.
- 10.8 Approval of the works and services shall not be granted until the conditions for the installation of works and services have been fulfilled; reproducible as-built drawings and an engineer sealed as-built certificate of bylaw compliance acceptable to the Approving Officer have been submitted.
- 10.9 All engineering works and services required for a subdivision or development by the Approving Officer or this Bylaw or any other Bylaw of the District shall be constructed in accordance with the Master Municipal Construction Documents as incorporated by reference in this Bylaw and this Bylaw. Should any conflict exist between these documents, this Bylaw shall take precedence over the Master Municipal Construction Documents.
- 11.0 **SUBDIVISION APPROVAL**
- 11.1 An application for subdivision shall be made on the applicable form prescribed in Schedule "D".
- 11.2 All of the items required in the application form in Schedule "D" shall be submitted with an application for subdivision approval.
- 11.3 No person shall amend any approved plan of subdivision or any approved design drawings or specifications without first having obtained the approval of the Approving Officer in writing.

## 12.0 SERVICING SECURITY REQUIREMENT

12.1 All Works and Services required to be constructed and installed at the expense of the owner of the land being subdivided shall be constructed and installed to the standards prescribed in this Bylaw before the Approving Officer approves of the subdivision, unless the owner:

- (a) Deposits Security with the District, having regard to the cost of installing and paying for all the Works and Services;
- (b) Enters into an agreement with the District in the form(s) of Schedule D, accepting the terms and conditions in the agreement and undertaking to construct and install the required Works and Services or to forfeit the Security to the District; and
- (c) the Security shall be in the amount of 110 per cent of costs of constructing and installing the Works and Services, as reasonably estimated by the Approving Officer.

## 13.0 BYLAW COMPLIANCE

Any person who violates any provision of this Bylaw commits an offence and shall be liable on summary conviction to a penalty not less than one thousand dollars (\$1,000.00) and not exceeding five thousand dollar (\$5,000.00) and costs of prosecution. The penalties imposed under this sub-section shall supplement and shall not substitute for any other remedy to an infraction imposed by this Bylaw.

## 14.0 INCORPORATION OF DOCUMENT BY REFERENCE

The Master Municipal Construction Documents published in 2000 by the Master Municipal Construction Documents Association, a copy being filed in the Office of the Administrator of the District of Highlands' on December 5, 2000, is hereby incorporated by reference into and forms part of this Bylaw.

READ A FIRST TIME THIS	7 <sup>th</sup>	DAY OF	MAY, 2001
READ A SECOND TIME THIS	7 <sup>th</sup>	DAY OF	MAY, 2001
READ A THIRD TIME THIS	7 <sup>th</sup>	DAY OF	MAY, 2001
ADOPTED THIS	22 <sup>nd</sup>	DAY OF	MAY, 2001

---

MAYOR

---

CLERK

## SCHEDULES

Service Level for Works and Services (in each zone) Standards for Services

SCHEDULE A:	Service Level for Works and Services (in each zone)
SCHEDULE B:	Standard for Service
Section D	- Standards for Storm Water Management
Section G	- General
Section R	- Standards for Roads
Section S	- Standards for Sanitary Sewerage Systems
Section W	- Standards for Electrical, Telephone, Street Lighting and other services supplied through wires
Section WA	- Standards for Water Service and Fire Protection
Section WT	- Standards for Walkways and Trails
SCHEDULE C:	Supplementary Details Drawings
SCHEDULE D:	Standard Forms
SCHEDULE E:	Bare Land Strata Service Levels
SCHEDULE F:	Building Permit Service Levels

**SCHEDULE A**  
**SERVICE LEVEL FOR WORKS AND SERVICES**

ZONE CATEGORY	ROADS	ELECTRICAL/ WIRING	WATER	STORM WATER	SANITARY SEWAGE	WALKS/ TRAILS
RURAL RESIDENTIAL	1	1	1 or 2	1	1	1
RURAL	1	1	1	1	1	1
GREENBELT	1	1	1	1	1	1
PARK	1	1	1	1	1	1
WATER	1	1	N/A	1	N/A	1
GENERAL INDUSTRIAL	1	1	1	1	1	1
CONSERVATION	1	1	1	1	1	1
COMMUNITY	1	1	1	1	1	1

## SCHEDULE B

### SECTION D - STANDARDS FOR STORM WATER MANAGEMENT

#### D.1 GENERAL

- 1.1 A storm water management system is to be designed and constructed for all subdivisions or developments subject to this bylaw. The system is to be designed by a Professional Engineer, taking into account the existing drainage conditions in the entire watershed in which the development is located, so that for all events up to the predicted 1 in 200 year rainfall event, there is no increase in water levels or rates of erosion at any point in the watershed as a result of the subdivision or the development compared to the pre-existing conditions, prior to the removal of any natural vegetation from the site.
- 1.2 The above requirement shall apply to the temporary conditions on site during construction and to the completed development or subdivision.
- 1.3 The storm water management system, design, and construction shall be in accordance with the requirements of this Section and the drainage system in the subdivision or development shall be fully integrated with the systems in adjoining areas.
- 1.4 Service Level 1 requires a drainage system where existing soil or site conditions make a drainage system necessary to protect the established amenities of adjoining properties or roads. Where a drainage system is required a ditch may be permitted which flows to an infiltration system, a watercourse or other ditch acceptable to the Approving Officer and the Ministry of Environment.
- 1.5 Service Level 2 requires an enclosed storm drain system installed by the owner complete with service connections to serve all parcels and roads being created by subdivision at a depth and of capacity sufficient to serve the upstream catchments area including the proposed subdivision. The system shall discharge to an infiltration system, a watercourse, ditch or enclosed drain acceptable to the Approving Officer and the Ministry of the Environment.
- 1.6 This specification shall govern the design of all drainage facilities within the District.
- 1.7 The District reserves the right to make all connections or alterations to existing storm drain systems at the expense of the Applicant where it can be demonstrated that such works are necessary to accommodate the Applicant's development.

- 1.8 All drainage works shall be designed with considerations for public safety, regulatory requirements, economic benefits and the natural environment.
- 1.9 The presence of an existing municipal drainage system does not mean, or imply, that the system has adequate capacity to receive the proposed design flows, nor does it indicate that the existing system pattern is acceptable to the District. Existing facilities, which are undersized or inadequate to accept additional drainage, must be upgraded at the Developer's expense to accommodate the appropriate flows. Alternative drainage proposals may be considered.
- 1.10 It must be shown that all downstream drainage facilities for a distance of 3 km beyond the development are capable of handling any projected increase in runoff created by the proposed development.
- 1.11 Adequate erosion and sediment control is required for all developments or works discharging runoff into the municipal drainage system and/or natural watercourses.
- 1.12 Infiltration trenches and drywells are permitted where the native soils demonstrate high permeability and the groundwater table is well below the invert of the trench. Design must be site specific and possibly include a positive drainage outlet.
- 1.13 Designs and plans shall be reviewed and approved by the Approving Officer prior to construction.

## D.2 STORMWATER MANAGEMENT PRINCIPLES

- 2.1 Storm Water Management is the planning, analysis and control of storm runoff in consideration of the entire watershed. The design of the drainage system shall incorporate techniques such as minor-major systems, lot grading, surface infiltration, subsurface disposal, storage, erosion control and other acceptable methods to mitigate the runoff impacts due to changes in land use.
- 2.2 A comprehensive Storm Water Management Plan is required for all developments except in areas where no lots less than 2 ha in area are permitted. This requirement may be waived in writing by the Approving Officer. The plan shall include all drainage facilities, lot grading (showing pre and post-development ground elevations), major flood path routing, and all other appropriate information pertinent to the design.
- 2.3 Minor systems, being those designed and installed as part of the works and services for the subdivision or development, must be designed for a 1-in-10 year rainfall event, providing the existing overland flow system will not have any increase in flow in a 1-in-200 year rainfall event.

- 2.4 The design must create an overland route within the subdivision or development for the 1:200 year rainfall event to allow for the failure of the minor drainage system. This route must be protected and have a right-of-way in favour of the District.
- 2.5 Where, in the opinion of the Approving Officer, future development or subdivision is probable for the lands adjacent to the development or subdivision, storm drainage must be extended to the property boundary in accordance with this Bylaw. A right-of-way in favour of the District must be provided for this storm sewer on private property for access and maintenance.

### D.3 DESIGN CRITERIA: RUNOFF PREDICTION

- 3.1 A Tributary Area Schematic diagram of the Drainage System shall be submitted which includes the following:
- The existing drainage system, if a system exists, shall be indicated in solid blue pencil.
  - An outline in red pencil of the proposed storm system from the existing upstream storm system to the downstream end of the subdivision or development. Storm sewer pipe together with any retention or detention structures proposed to be installed should be shown with a solid line and proposed ditching with a broken “squiggly” line. The schematic shall show the pipe diameter and grade and ditch grades.
  - An outline of the drainage area in a solid green line, indicating the tributary area of all surface water added to the proposed storm system below the last existing storm outfall. When the subdivision or development is at the upper end of the drainage system, the green line shall outline the tributary area of all water added to the proposed storm system.
  - A broken green line indicating within this drainage area, the subareas of additional drainage added at each tributary drainage facility.
  - The calculated numerical values of major and minor flows  $Q$  in litres per second, Tributary  $A$  in hectares and Time of Concentration  $T$  in minutes at the downstream end of the subdivision. When the subdivision or development is not at the upper end of the drainage system, the same information noted above shall be provided at the upstream end of the subdivision or development.
- 3.2 It shall be the responsibility of the Consulting Engineer to summarize drainage computations pertaining to that project and submit this data for approval together with the above diagram.
- 3.3 The intensity-duration curve to be used shall be that of Supplementary Detail Drawing SDD#1.

- 3.4 The following minimum values shall be used for the inlet time to the upstream end of non- extendable drainage works for the coefficient of runoff (R):
- a) Unimproved areas, parks, playgrounds, etc. - inlet time to be determined using standard engineering practice acceptable to the District and  $R = 0.35$ .
  - b) Residential areas - low density, single family dwelling neighbourhoods – inlet time = 15 minutes and  $R = 0.60$ .
  - c) Largely impervious areas – inlet time = 5.0 minutes and  $0.90 < R < 1.0$ .

The above standards are minimum values only. Composite values based on percentages of different types of contributory areas may be established from the above figures. Care should be taken to incorporate future land use in the design.

- 3.5 French drains, diversion ditches, catch basins, etc. shall be installed as required in areas subject to excessive overland flows.

#### D.4 DESIGN CRITERIA: PIPE and DITCH CAPACITY

- 4.1 Pipes shall be designed to carry the required design flow when flowing full except for pipes carrying flows less than that required for the minimum pipe size.
- 4.2 Pipe capacity is to be determined by the Manning Formula using a roughness coefficient of  $n = 0.013$  except that  $n = 0.015$  for C.M.P.
- 4.3 The minimum grade for storm drains shall normally be that which produces a velocity of 1.0 metres per second in the pipe when flowing full. Maximum pipe full flow design velocity allowed is 3.5 metres per second.
- 4.4 Service connections for single family dwellings shall be 100mm minimum diameter pipe laid at a grade not less than two percent and connected to the main as shown on MMCD Drawing S8 with monolithic wyes, tees, or hubs of acceptable design and material.
- 4.5 Service connections for other than single-family dwellings shall be sized according to the criteria contained in the B.C. Plumbing Code. Manholes shall be installed at the junction with the main line of all service connections greater than or equal to 200mm in size.
- 4.6 Main storm drains shall not be less than 200mm in diameter.
- 4.7 Catch basin leads shall be minimum 150 mm diameter laid at a minimum grade of one percent. Only a single catch basin will be connected to each lead and double catch basins shall have separate leads to the main.

- 4.8 Catch basins as detailed in MMCD Drawing S11 shall be provided as required to collect from a maximum area of 400 square metres of road, at the beginning of curb returns to which water flows and at low points. Rim elevations shall be 30 mm below finished pavement grade. Side inlet catch basins shall be installed at low points and in locations required in the opinion of the District.
- 4.9 Open ditches to be constructed in accordance to Supplementary Detail Drawing SDD#2 and shall enter an enclosed storm drain system through an inlet as per MMCD Drawing S13. The pipe accepting the flow from the ditch shall be a minimum 300 mm diameter.
- 4.10 Sandbag outfall structures shall be provided where the storm system discharges into an open channel other than a watercourse. The end of the storm sewer shall project 300 mm from the toe of the backfill and shall be placed on standard sandbags filled with 17 MPa dry concrete mix in accordance with MMCD Drawing S15 (replace concrete blocks with sandcement bags). The area around and over the storm sewer shall be built up with sandbags to a height of two rows of sandbags over the storm sewer pipe. A rock riprap apron or other velocity dissipating structure shall be placed immediately downstream.
- 4.11 Driveway culverts shall be a minimum 300 mm diameter. Headwalls shall be as per MMCD Drawing S15 (replace concrete blocks with sand-cement bags or mortared rock).
- 4.12 Cast in place reinforced concrete outfall structures shall be provided at all watercourses. In all cases energy dissipation shall be provided to reduce maximum outlet flow velocity to 1.0 m/s.
- 4.13 Wherever an open channel or pipe system is not feasible for storm water management due to a lack of point of discharge or other reasons, an in-ground storm water disposal system may be considered subject to the following:
- a) A geotechnical report of the soil condition by a qualified consultant;
  - b) A Professional Engineer designed seepage pit complete with size, location, specified material, an inlet structure and a positive emergency drainage outlet.

## D.5 FIELD SUPPORT STRENGTH

- 5.1 The class and type of pipe and fittings, together with required class of bedding and trench widths shall be so selected that the pipe will support the anticipated gravity earth and any surface dead and live loads with a safety factor of 1.5. Highway standard H20 loading is a minimum design load.
- 5.2 Notwithstanding the generality of paragraphs 5.1 and 6.1, the following minimum requirements shall be met.
- a) Minimum cover for PVC pipe shall be 0.75 m. For installation under areas used for vehicular traffic, minimum cover shall be 1.0 m.
  - b) Minimum cover for rigid pipe, corrugated steel pipe, and high-density polyethylene pipe, shall be 0.5 m. For installation under areas used for vehicular traffic, minimum cover shall be 1.0 m, except for catch basin leads.

## D.6 ALIGNMENT AND GRADE

- 6.1 Pipe lines shall be normally designed to follow a straight alignment and constant grade between manholes.
- 6.2 Whether horizontal or vertical, curves will only be acceptable when a straight alignment and constant grade between manholes is not possible.
- a) The radius of a horizontal curve shall be not less than 60 m, or that radius recommended by the pipe manufacturer, whichever is the greater.
  - b) A vertical curve must not be less than 30 m in length. The curve must be designed so that the pipe deflection does not exceed the manufacturer's specifications.
  - c) Only one curve, either horizontal or vertical, may be permitted between manholes.

## D.7 LOCATION OF SERVICES

- 7.1 Storm drains should be located within the road allowance where possible. Service connections shall be installed to each proposed lot, connected to the main, and where feasible in a common trench with other services.
- 7.2 In locating the storm drain, the designer shall make provision for the installation of other services such as watermain, sewers, curbs, sidewalks, gas, power, and telephone facilities.
- 7.3 Service connections shall be extended to the edge of any right-of-way.

7.4 Where storm drains can be extended to accommodate future subdivisions upstream, the main shall be extended to the limits of the subdivision, and cleanouts or silt traps shall be installed at those locations at the developer's expense.

## D.8 MANHOLES AND CLEANOUTS

8.1 The maximum distance between storm drain manholes may vary according to the pipe diameters as shown in the table below:

PIPE SIZE	MAXIMUM SPACING
200mm up to and including 375mm	120 metres
400mm up to and including 1200mm	180 metres
over 1200mm	300 metres

8.2 Manholes shall be provided at the following additional locations:

- a) At all changes of grade and/or alignment, except as provided in section 8.1 of this specification;
- b) At all changes of pipe size;
- c) At all pipe junctions other than service connections and catch basin leads.

8.3 Drop manholes may be allowed only where particular circumstances preclude the use of normal manholes. These shall be constructed wherever the change in invert elevations through the manhole is greater than 0.60m. Allowance must be made in the design for the effect of the resulting turbulence on the hydraulic capacity of the system.

- 8.4 The relative elevations entering and leaving a manhole are to be such as to ensure that the manhole does not reduce the hydraulic capacity of the system. Allowances for energy losses or changes in velocity are to be determined in accordance with sound hydraulic principles. Junctions shall require special treatment as shall all situations involving a pipe flowing into a smaller pipe on a steeper grade.
- 8.5 Manholes are normally constructed in accordance with the details as shown on MMCD Drawings S1, S2, and S3. In cases where these details will not suffice, a detailed design drawing shall be submitted to the Approving Officer for consideration. All manholes with pipes 450mm or larger must be individually designed.
- 8.6 Stubs shall be placed in manholes to allow for future connections. The length of the stubs shall be 0.60 m maximum from the outside of the manhole unless otherwise requested and the end shall be securely capped.
- 8.7 Cleanouts shall be installed at the end of all storm drain lines.

## SECTION G - GENERAL

### G.1 INTRODUCTION

- 1.1 The purpose of this section is to outline the minimum standards and requirements the District will accept in the design and as-built drawing submissions for engineering works. Quality submissions of design and asbuilt drawings are expected.
- 1.2 Incomplete or substandard submissions will be returned to the Developer's Engineer without comment on the drawings and with a short letter of explanation as to why the drawings are being returned.
- 1.3 All engineering surveys shall be conducted in a safe manner so as to not create a nuisance to traffic or the public at large. The permission of the registered owners is required before entering private property.

### G.2 GENERAL

- 2.1 Any information received from the District on existing services shall be used as a guide only. Verification of locations and elevations must be checked by actual survey. The District takes no responsibility for the exactness of service information obtained from our files and drawings.
- 2.2 Elevations shall be shown in metric geodetic datum. All survey work must be tied into an accepted benchmark whose datum was supplied by the District. The reference benchmark and elevation shall be shown on the design drawing.
- 2.3 Show the elevation of all existing basement floors and minimum basement

elevations (MBE's) where critical.

- 2.4 All existing rights-of-way and their permitted uses must be checked through the Land Titles Office and be shown lightly shaded on the design drawing.
- 2.5 All proposed rights-of-way for new services shall be shown as a dashed line. These shall be tied to the iron pin in each lot, together with their width, permitted use, and the note "acquire" or "proposed." Right-of-way documents shall be prepared to the District's approval.
- 2.6 A north arrow, existing and proposed road names shall be shown on the design drawing.
- 2.7 All services shall be shown on one plan with curbs, sidewalks, sewers, drains, water, and underground wiring and poles identified as MC or NMC, S/W, S, D, W, and U/G, H or T respectively.
- 2.8 Indicate existing watermains, fire hydrants, sanitary sewer mains, storm drains (including all appurtenances), ditches, pavement, curbs, sidewalks, underground wiring, gas lines, underground ducting, poles, fences, hedges, existing buildings, unusual ground conditions, wells, septic systems, water courses, ponds, lakes, and service connections in plan and profile.
- 2.9 Drawings must show all proposals for construction which are not covered or specifically detailed in this bylaw's standards or specifications. It is not always necessary to include details for which there is in the MMCD or this bylaw a Standard Drawing. Standard Drawing numbers may be quoted.

### G.3 DRAWING INFORMATION

- 3.1 All drawings shall be prepared in accordance with the following requirements and all other requirements of this Schedule.
- 3.2 All design submissions shall have an original dated signature and seal of a Professional Engineer registered in British Columbia. Failure to do so will result in the plans being returned without comment. The Developer's Engineer's seal and original signature with date shall infer that all works as proposed are structurally sound, comply with the applicable design criteria of this bylaw, and good engineering practice.
- 3.3 All drawings shall be stenciled and shall clearly identify the works in sufficient detail. Road cross-sections may be by hand, provided they are of good quality and clarity.
- 3.4 Where applicable, cross-sections will be required. The sections shall include

centreline, edge of pavement or gutter line, edge of shoulder, ditch invert, top of ditch, trail or pathway, property line, and an existing ground elevation inside property line.

- 3.5 Standard sheet size is A1 metric size 594mm x 841mm.
- 3.6 Use transparent plan/profile paper complete with title block in the lower part of the sheet making reference to the District of Highland's correspondence file number.
- 3.7 Dimensioning of drawing shall be given from an existing or proposed iron pin or lot line.
- 3.8 All new works are to be drafted in bold lines.
- 3.9 Road chainage shall be tied to an iron pin from the start of construction.
- 3.10 Plans shall show the legal layout of roads and properties, with all legal descriptions (lots and plan numbers) and dimensions (to the nearest 0.01m). Also show existing house numbers and registered statutory rights-of-way.
- 3.11 A cover sheet shall be prepared and attached to the front of all drawing sets. The cover sheet shall note the Developer's Engineer's name, the Developer's name, address, telephone number and fax number, the District's File Number, the legal description of the lands involved, a site plan at a 1:5000 scale, and a drawing index. The plan shall note all proposed roads and the proposed subdivision layout. The cover sheet may be utilized to show the drainage catchment's area.

#### **G.4 REQUIREMENTS FOR SUBDIVISION KEY PLAN**

- 4.1 A key plan shall be provided, to scale 1:2500, and shall include the following information:
  - a) Plan of adjacent roads and existing lots with roads named and legal description of adjacent lots given;
  - b) The civic address and shade the property being subdivided;
  - c) A north arrow;
  - d) Contours at 2.0 m intervals except on very steeply sloping ground, where 5 m intervals will be accepted;
  - e) If the subdivision is to be developed in stages, each proposed stage shall be clearly outlined and order of development indicated; and
  - f) Location of existing survey monuments.

#### **G.5 REQUIREMENTS FOR STORM WATER MANAGEMENT PLAN DRAWINGS**

- 5.1 These shall be at an acceptable scale and identified as per key plan system if more than one sheet is required. The Storm Water Management Plan shall include:
- a) Contours as per Section G.4 extending a minimum of 200 m outside the development site;
  - b) Any areas of cut or fill are to be indicated with existing property pin elevations uncircled and proposed elevations circled. Fill over 0.5 m is to be shaded, with fill over 1 m highlighted;
  - c) The proposed building envelope for each lot is to be shown along with the minimum building elevation (MBE);
  - d) The minor (1:10 year) storm drainage system with the flows as per Section D of this Schedule;
  - e) The major (1:100 year) storm drainage system with the flows noted as per Section D of this Schedule. Provision must be made for upstream development;
  - f) All swales and ditches as well as existing channels required in the Storm Management Plan. Easements required over any lot accepting directed drainage from upstream lots; and
  - g) No increase in surface drainage flowing off site over adjacent lands unless provision is made for offsite works to be constructed in compliance with District standards.

#### G.6 REQUIREMENTS FOR ROAD OR PARKING AREAS DRAWINGS

- 6.1 Show all iron pins adjacent to the works and the existing ground elevation at each pin or proposed pin.
- 6.2 Both plan and profile must be tied to an iron pin, preferably near or at 0+00 chainage. If the chainage exceeds 120 m, a second tie shall be shown.
- 6.3 Show the road width, curb, edge of pavement and sidewalk offsets measured from the property line where applicable.
- 6.4 Road profiles shall show the gutter of curb and/or centreline of road elevations.
- 6.5 Detail the road construction with a typical cross-sectional view.

- 6.6 The profile shall be shown at true centreline length and provided in as close relationship as possible to the plan.
- 6.7 Locate catch basins in accordance with specifications.
- 6.8 Locate barricades.
- 6.9 Locate ditches and centre of pavement in road construction by offsetting to property line.
- 6.10 Existing and proposed critical driveway locations within the subdivision shall be shown as well as a profile of each driveway from the road centreline to the end of the driveway within the property.
- 6.11 Chainage of the BC and EC for horizontal curves shall be shown together with the centreline radius. Curb radii are not required if the centre line radius and road width are shown, except on curb returns at intersections if other than 8m, at the end of cul-de-sacs, and on any curbs where alignment is not directly related to the centreline radius.
- 6.12 The percent grade to two decimal places shall be shown on the profile together with the following information on vertical curves:
  - a) The station and elevations of BVC, EVC, and VPI;
  - b) The external value;
  - c) The length of vertical curve;
  - d) The elevation and station at 20 m stations and the low spot of sag curves;
  - e) The % grades of the adjacent vertical alignment; and
  - f) The K value for vertical curves.
- 6.13 On super elevated curves and cul-de-sacs on vertical and horizontal curves, show a profile of each curb or the edge of pavement (no centreline profile).
- 6.14 Road cross sections shall be scaled at 1:100 horizontal and 1:50 vertical and shall note the existing ground elevation, the proposed elevations of the road centreline, the curb and gutter (or road edge), the invert and top of any ditches, centreline of trails or walkways, and property lines. Cross sections are required at 20m intervals. Additional sections may be required or requested where excessive cuts or fills are involved. These plans may be by hand, provided they are of good quality and clarity. Side and back slopes are to be shown. Each sheet shall have a typical cross section.
- 6.15 Show pavement markings and traffic control signs on all drawings.

## G.7 REQUIREMENTS FOR SEWER AND DRAIN DRAWINGS

7.1 The following information shall be shown on the profile:

- a) Size, type and class of pipe, class of bedding;
- b) Percent grades to two decimal places. If critical, mark "CR" after the grade, if not critical, show the minimum grade thus: (1.08% min.);
- c) Give invert elevations at both inlet and outlet of manholes;
- d) Give rim elevations on all manholes and catch basins;
- e) Show existing Sewer and Drain where required.

7.2 The following information shall be shown on the plan:

- a) Information on horizontal curves as detailed in paragraph 6.11;
- b) Indicate pipe offsets from property line; and
- c) Indicate the grade of any service connection from the upper end to the drop to the main if other than two percent.

7.3 The following additional information shall also be shown on the appropriate part of the drawing:

- a) Sanitary sewer manholes and cleanouts shall be lettered;
- b) Storm drain manholes, cleanouts and silt traps shall be numbered;
- c) Structural detail of all manholes not covered by MMCD Standard Drawings;
- d) Cross sections and plan views of any swales or ditches required for the development;
- e) Details regarding any storm water retention or treatment facilities required for the development;
- f) Where an open ditch drainage system is proposed, note the size of future driveway culverts required to conform to the design.

7.4 The information requested in Section S for on-site sanitary sewerage systems shall be shown and detailed on a suitably scaled drawing. Information and details regarding soils tests, treatment proposed and sewage disposal system proposed shall be adequately and accurately detailed and noted on the drawings or attached submissions.

## G.8 REQUIREMENTS FOR UNDERGROUND WIRING AND POLES DRAWINGS

- 8.1 Dimension the offset from property line and/or iron pins of the existing underground conductors or mains and the location of all appurtenances related to the system including house connections. Refer to the appropriate utility for complete details of existing underground installations. Offsets to be verified through the appropriate utility.
- 8.2 Show proposed overhead underground hydro/telephone/cable service schematically.
- 8.3 Dimension the location of all poles, both existing and proposed, from the pole surface face to property line and/or iron pin.

## G.9 REQUIREMENTS FOR ROAD LIGHTING DRAWINGS

- 9.1 Location, type and wattage of luminaries complete with ducting information to be shown.
- 9.2 Details of service base and wiring is to be shown if not as per standard drawings.

## G.10 REQUIREMENTS FOR WATER DRAWINGS

- 10.1 The following information shall be shown on the plan and profile drawings:
  - a) Size, type, and class of pipe;
  - b) Class of the pipe bedding;
  - c) Elevations and grades of the pipe;
  - d) Ground profiles and pipe cover; and
  - e) Valves, bends, fire hydrants, other appurtenances, etc. are to be shown and chainages noted.
- 10.2 The full pipe shall be shown for the watermain on the profile.
- 10.3 All crossover points with sewers shall be noted and where the watermain is below any sewer, or is less than 0.5 m above any sewer, the watermain shall be shown to be protected in accordance with Ministry of Health requirements.
- 10.4 The design drawings for the Water Supply System of Sub-section WA-4 for Service Level 2 shall be provided to Island Health for approval. These shall indicate all details required for the works on a suitably scaled drawing all to the approval of Island Health.

*\*amended under Bylaw 371, 2016*

## G.11 DESIGN AND DRAWING SUBMISSIONS

11.1 The first complete design submission shall consist of:

- a) two complete sets of drawings;
- b) two additional storm water management plans;
- c) nine additional key plans;
- d) two additional streetlighting plans;

*\*amended under Bylaw 371, 2016*

- e) four additional sets of Water Supply System drawings including a site and key plan with each set, together with a copy of the completed application to the Comptroller of Water Rights and Island Health which was submitted for their approval;

*\*amended under Bylaw 371, 2016*

- f) two additional sets of sanitary sewerage system drawings including site and key plan with each set, together with a completed application to Island Health or the Ministry of Environment as applicable;
- g) soils report to verify road structure design for all new road construction; and
- h) all applicable utility calculations (water, sanitary, storm drainage) and reports requested earlier.

11.2 Subsequent design submissions requiring changes to the previous submission shall consist of :

- a) two complete sets of drawings;
- b) any changes made by the Developer's Engineer's which are in addition to "Red Line" changes required by the District shall be highlighted in yellow;
- c) all items "Red Lined" by the District must be addressed by the Developer's Engineer or the submission will be returned.

11.3 The final submission for District acceptance shall consist of :

- a) four complete sets of drawings;
- b) two additional storm water management plans;
- c) four additional key plans; and
- d) one additional road lighting plan.

## G.12 AS-BUILT DRAWING SUBMISSION

- 12.1 The Developer's Engineer shall submit two complete sets of paper prints, except for the road cross-section sheets.
- 12.2 One marked-up set of the as-built drawing paper prints will be returned to the Developer's Engineer for revision. If there are minor changes, the mylar may be revised. If amendments are numerous, it is likely that the Developer's Engineer will be requested to resubmit two sets of revised paper prints for a second review. The District's File Number will have been noted on each drawing for identification of the mylar drawings.
- 12.3 As-built drawings shall be presented as follows:
- a) A new key plan at a 1:1000 scale noting water, sanitary, storm drainage works, streetlights, roadworks, benchmarks and monuments. The plan shall show the as-constructed offsets for those works and the locations of all service connections relative to the lot lines;
  - b) Detailed plan profile drawings for water, sanitary, storm and roadworks. Elevations, inverts and offsets to show the works as constructed. The profile drawings for the utilities shall state the pipe materials used;
  - c) Where required in the design submission, the stormwater management plan including any lot grading performed. The plan shall note the elevations at all lot corner pins, lawn basin and catch basin rims, culverts and swale inverts. Grades in graded areas shall be uniform unless indicated otherwise on the plan (to a tolerance of  $\pm 300$  mm). In no case shall the lot grade be less than the minimum;
  - d) Street light drawings shall show make, model and type of luminaire unit and locations of service bases and photocells except those provided by B.C.Hydro;
  - e) Plans of details for which there is no Municipal standard (pump stations, water wells, treatment plants, etc.);
  - f) In all cases notes with instructions to the Contractor are to be removed or amended to indicate the results of construction. Previously existing works that have been deleted as a result of construction, or reconstructed in accordance with design shall be removed or amended to show works as constructed. It is intended that the as-built drawings shall show the works as they have been constructed in order to provide accurate and detailed information when adding to, or maintaining, the works shown on the plans.

12.4 When the District is satisfied with the Record (as-built) Drawings submission, the Developer's Engineer will be requested to submit the following:

- a) One set of 3 mil mylar drawings identified in bold letters with the words "CERTIFIED RECORD DRAWINGS". Mylars shall be uniform in background and foreground colouring with no pieces taped together. Mylars will not be signed or sealed. The District File Number must be added to each drawing;
- b) Two sets of paper prints with the following certification: "I certify this drawing represents the works and services as designed, installed, and inspected."

The signature and seal shall be by the Engineer who personally performed or personally supervised the required inspections. The District will return one set to the Developer's Engineer upon acceptance;

- c) One set of drawings, in Vectorworks DWG or DXF format, identified in bold letters with the words "CERTIFIED RECORD DRAWINGS". The District File Number must be added to each drawing. Drawing files are required to:
  - i) be opened using an unaltered copy of Autocad (no third party entities, fonts etc.);
  - ii) be constructed entirely in model space;
  - iii) have the colour of entities modifiable by changing layer colours (blocks must be built on layer 0 with colour by layer).
  - iv) be plotted by using extents and a fit scale (or noted scale on the appropriate paper size).
- d) One copy of the "Certificate of Inspection" (Form F-10). This form is to be signed by the Developer's Engineer.

12.5 When a development does not require a Servicing Agreement (i.e. site plan review, etc), the Developer's Engineer shall provide 5 sets of as-built drawings. Pertinent information shall include service connection sizes and locations, driveway widths, light standard locations, and a stormwater management plan including MBEs.

12.6 The following results and information shall be provided as part of the consultant's "as-built" submission:

- a) Roads
  - i) Compaction test results on base and sub-base;
  - ii) Material test results pertaining to gravel, asphaltic materials and concrete;
  - iii) Geotechnical certification of rock faces and rock fill;
  - iv) Structural certification of retaining walls.

b) Sewers and Drains

- i) Results of air tests;
- ii) Video inspection results where required;

c) Water

*\*added under Bylaw 371, 2016*

- i) Island Health construction permits and approvals.
- ii) Chlorination and pressure test results on watermains;
- iii) Hydraulic flow test results;
- iv) Certificate of Public Convenience and Necessity for Service Level 2;
- v) Results of water quality and quantity study of well(s).

d) Electrical

- i) Provincial Electrical Inspectors Certificate.
- ii) Confirmation of B.C. Hydro connection made and all fees paid

e) Sewage Treatment and Disposal Systems

*\*amended under bylaw 371, 2016*

- i) Island Health and/or Ministry of Environment approvals.
- ii) For strata sewage treatment plants a copy of the Provincial Electrical Inspectors Certificate and confirmation of B.C. Hydro's connection being made with all fees paid.

## SECTION R-STANDARDS FOR ROADS

1. All roads in the District shall be designed in accordance with the recommended practice as outlined in the latest edition of the "Manual of Geometric Design Standards for Canadian Roads" as published and amended from time to time by the Canadian Transportation Association (TAC) or as stated elsewhere in this Schedule or as accepted by the Approving Officer.
2. Roads shall have a minimum right of way width of 20 m.
3. Cul-de-sac roads shall be provided at the closed end with an area designed to permit safe and adequate space for turning of motor vehicles.
4. Maximum slope on a cul-de-sac is 8%. The minimum property line radius of turning areas at the end of cul-de-sac roads shall be 15 m.
5. The design of cul-de-sacs is not limited to the above and the designer may propose alternatives provided that good engineering practise is followed. Alternative designs are subject to review by the Approving Officer.

6. Intersecting roads boundaries shall be rounded to a 6 m radius curve. The edge of pavement or curb return radius shall be 7m.
7. Jogs in road alignment at intersections shall be permitted, provided the distances between centre lines at the jog is a minimum of 80m, unless it is impractical to comply because of the existing road configuration.
8. Intersecting roads shall meet substantially at right angles. In no case shall roads intersect at an angle of less than 80 degrees. Grades of roads at intersections shall be adjusted where topographic or other conditions dictate the use of maximum or near maximum permissible grades. Such adjustments are essential to provide reasonable stopping opportunities during extreme roadway slippery conditions.
9. Roads are to be laid out with due regard to the topography so as to avoid flat or excessive grades. The maximum allowable road grade is 12%. The minimum allowable longitudinal road grade is 0.5%.
10. Standard cross-slopes on roads shall be 2% with the crown point in the centre of the pavement. Where topography is involved, local roads may be designed with cross-slopes from 1% to 3% and with one-way cross falls subject to the acceptance of the Approving Officer.
11. The design speed for country roads is 30kmph, for local roads is 40kmph and for Millstream Road 50kmph.
12. Any roads longer than 500 metres are classified as local roads except for Millstream Road.

*\*Added under Bylaw 334, 2012*

13. The width of asphalt paving shall be as indicated in the following table:

ROAD TYPE	SERVICE LEVEL 1	SERVICES LEVEL 2
Cul-de-sacs less than 200m long	5.4m	8.6m
Country road	5.4m	8.6m
Industrial road	8.6m	n/a
Local road	6.6m	8.6m
Millstream road	n/a	11.6m

14. The design of new roads shall be based on the results of the analysis of materials from test holes dug on the proposed road site at representative intervals. A qualified soils test company shall take test holes and samples and all reports shall be signed and sealed by a qualified Geotechnical Engineer.

15. Paved pullouts shall be provided at all locations for group mailboxes. They shall be 4.5m wide, 8m long, and have 10m long tapers on each end.
16. Where applicable, the road design shall ensure that the road cross-sections are established to accommodate the 1:200 year Flood Path Routing.
17. If cut or fill slopes, including any required for trail or walkway construction on the roadway, extend beyond the road allowance, a right-of-way sufficient to support the slope plus 1 m shall be registered in favour of the District.
18. Service Level 1 requires machine laid asphalt with crushed gravel shoulders as per Supplementary Detail Drawing SDD#3. Service Level 2 requires machine laid asphalt with concrete curbs integral with a concrete gutter as per Supplementary Detail Drawing SDD#4 or Supplementary Detail Drawing SDD#5".  
*\*Amended under bylaw 334, 2012*
19. The entire area of all roads shall be brought to the designed grades and shapes. All unsuitable material shall be removed and replaced within the right-of-way. Where possible existing trees and vegetation shall be preserved within the right-of-way. Any disturbed area shall be revegetated to the satisfaction of the Approving Officer.
20. The District, at the Developer's expense, will install all traffic signage and pavement markings required for each project.
21. Driveway access grades shall be designed to permit the appropriate vehicular access for the zone, without "bottoming-out" or "hanging-up". From the edge of pavement to the property line, the driveway shall follow proper boulevard slope to avoid flooding the road. For the first 10m on private property, the maximum driveway grade shall be 15%.
22. Designs and Plans shall be submitted to and must receive approval by the Approving Officer prior to construction.

## SECTION S-STANDARDS FOR SANITARY SEWAGE SYSTEMS

### S.1 GENERAL

- 1.1 Service Level 1 requires that each fee simple lot is provided with an approved design for a conventional onsite in ground sewage disposal system that is site specific for that lot; the system is not required to be installed prior to subdivision approval. Service Level 1 requires that each bare land strata lot be connected to a sanitary sewage collection, treatment, and disposal system all installed by the owner to serve all bare land strata lots created by the subdivision or be provided with an approved design for a conventional onsite in ground sewage disposal system, as per Section 2.1 which follows, that is site specific for that lot; the system is not required to be installed prior to subdivision approval.

- 1.2 Service Level 2 requires that all lots being created by the subdivision shall be connected to a sanitary sewage collection, treatment and disposal system.
- 1.3 Any existing in ground sewage disposal system in the development or subdivision shall be decommissioned and removed to the satisfaction of the Approving Officer if it is the intent of the developer to provide a new in ground disposal system.
- 1.4 For all fee simple subdivisions the Approving Officer refers the application to Island Health for an assessment of the suitability of the property for onsite sewerage treatment using Island Health subdivision standards. For all bare land strata subdivisions with common sewage systems the Approving Officer and either the Ministry of Environment or Island Health, whichever jurisdiction has the authority, must approve the design, construction and operational agreements of the sewage disposal system prior to subdivision approval.

## S.2 ON-SITE SANITARY SEWERAGE SYSTEMS

- 2.1 Single lot on-site sewage disposal areas for fee simple lots shall be assessed by an Island Health Environmental Health Officer (EHO) based on Island Health Subdivision Standards except that:
  - a) the design shall include a 100% reserve sewage absorption field that is based on field testing in the reserve area; and
  - b) the design drawings shall also indicate all siting and zoning restrictions, proposed building sites, driveway accesses, drainage facilities, water services, and accurate dimensions locating the proposed sewage works.

*\*amended under bylaw 371, 2016*
- 2.2 Multiple lots on-site sewage disposal systems shall be designed by, the construction supervised by, and as-built drawings and certification provided by an Authorized Person retained by the owner. This design shall be based on either Island Health Subdivision Standards and in accordance with the Sewerage System Regulation or the Ministry of Environment, whichever authority has the jurisdiction, except that:
  - a) the design shall incorporate common treatment by package treatment plant;
  - b) the design shall include a 100% reserve sewage absorption field that is based on field testing in the reserve area; and
  - c) the design drawings shall also indicate all siting and zoning restrictions, proposed building sites, driveway accesses, drainage facilities, and accurate dimensions locating the proposed sewage works.

*\*amended under bylaw 371, 2016*

*\*amended under bylaw 371, 2016*

- 2.3 On-site sewage disposal systems serving multiple lots shall be owned and maintained by the developer until such a time that a strata corporation is formed on common property or on a separate lot within the strata plan where the strata lots are located.

*\*amended under bylaw 371, 2016*

- 2.4 On-site sewage disposal systems serving multiple lots shall be served by a sewage collection system which is owned and operated by the developer until such time that a strata corporation is formed of the strata lots being serviced. The sewage collection system shall be designed and built according to Sub-section S.3 and S.4.

- 2.5 Multiple lot on-site sewage disposal systems shall be constructed as per the design approved in Sub-section S.2.2 and the requirements of this bylaw. The reserve sewage disposal field is not required to be built prior to subdivision approval.

### S.3 SANITARY SEWAGE COLLECTION SYSTEMS-EASEMENTS

- 3.1 Where sewers required to serve the subdivision are not in highways, the applicant subdividing the land shall grant to the strata corporation easements acceptable to the Approving Officer over land within the subdivision.
- 3.2 Where sewers required to serve the subdivision must cross over privately owned land outside the subdivision, the owner shall be responsible for obtaining the consent of the owner of such land to grant to the strata corporation easements providing for such services.
- 3.3 Where sewers required to serve the subdivision are in highways, the applicant subdividing the lands shall obtain from the District the required highways permit on behalf of the strata corporation to operate the sewage collection system on the highway.

### S.4 DESIGN OF SANITARY SEWERS AND SERVICE CONNECTIONS

- 4.1 This specification shall govern the design of all sewer pipe and sewer appurtenances within the District.
- 4.2 Design shall conform to the requirements of the Ministry of Environment, Waste Management Branch, "Guidelines for Assessing Sewage Collection Facilities" 1980 Edition, as amended from time to time, and the requirements noted in this Schedule.
- 4.3 Pipe shall be designed to carry the required quantity when flowing full.
- 4.4 Pipe capacity is to be determined by the Manning Formula using a roughness

coefficient of  $n = 0.013$  for smooth-bore pipe.

- 4.5 The minimum grade of sanitary sewers shall be that which produces a minimum velocity of 0.61 metres per second in the pipe. However, a velocity of 0.9 metres per second must be attained in the pipe above the last manhole of a non-extendable system.
- 4.6 Service connections for single family dwellings shall be 100mm minimum diameter pipe laid at a grade not less than two percent connected to the main with monolithic wyes, tees, or hubs of acceptable design and materials as shown on MMCD Drawing Number S7.
- 4.7 Service connections for other than single-family dwellings shall be designed according to the criteria contained herein for main lines and connected to the main as shown on MMCD Drawing Number S7
- 4.8 Main sanitary sewers shall not be less than 150mm in diameter.
- 4.9 All pipes shall be new, free of defects and be of the size and class shown on the design drawings.
- 4.10 The following pipe is permitted for sewers providing it is designated on the design drawing.

SIZE	MATERIAL AND CLASS	USE	CURRENT STANDARDS
100mm & up	Ductile Iron - 1035 kPa	where ground cover is less than 450mm, where ground cover is less than 750mm carrying vehicular traffic or similar loading within 750mm of a foundation	AWWA C151-76
100mm & 150mm	PVC Gravity Sewer Pipe rubber gasket with integral bell type PSM Poly (VinylChloride) Dimensional Ration (DR) of 28 with a pipe stiffness not less than 690 kPa	Service connections Catch basin leads (150mm)	CSA B182.1 ASTM D2412-73

- 4.11 The class and type of pipe and fittings, together with required class of bedding

and trench widths shall be so selected that the pipe will support the anticipated gravity earth and any surface dead and live loads with a safety factor of 1.5 for rigid and 1.9 for non-rigid pipe.

- 4.12 Notwithstanding the generality of paragraphs 4.11 and 4.13, the following minimum requirements shall be met.
- a) Minimum cover for PVC pipe shall be 0.75 m. For installation under areas used for vehicular traffic, minimum cover shall be 1.0 m.
  - b) Minimum cover for rigid pipe shall be 0.5 m. For installation under areas used for vehicular traffic, minimum cover shall be 1.0 m.
- 4.13 Pipelines shall be normally designed to follow a straight alignment and constant grade between manholes.
- 4.14 Any curve, whether horizontal or vertical, must be approved by the Approving Officer. Curves will only be acceptable under unusual topographical or subsoil conditions. In addition:
- a) The radius of a horizontal curve shall be not less than 60 m, or that radius recommended by the pipe manufacturer, whichever is greater.
  - b) A vertical curve must not be less than 30 m in length. The curve must be designed so that the pipe deflection does not exceed the manufacturer's specifications.
  - c) Only one curve, either horizontal or vertical, may be permitted between manholes.
- 4.15 The maximum distance between sanitary sewer manholes is 125 metres.
- 4.16 Manholes shall be provided at the following additional locations:
- a) At all changes of grade and/or alignment;
  - b) At all changes of pipe size;
  - c) At all pipe junctions other than service connections; and
  - d) Where the service connection is the same size as the main.
- 4.17 Drop manholes may be allowed only where particular circumstances preclude the use of normal manholes. These shall be constructed wherever the change in invert elevations through the manhole is greater than 0.60 m. Allowance must be made in the design for the effect of the resulting turbulence on the hydraulic capacity of the system.
- 4.18 The relative elevations entering and leaving a manhole are to be such as to ensure that the manhole does not reduce the hydraulic capacity of the system. In

addition:

- a) Allowances for energy losses or changes in velocity are to be determined in accordance with sound hydraulic principles.
- b) Junctions shall require special treatment as shall all situations involving a pipe flowing into a smaller pipe on a steeper grade.

4.19 Manholes are normally constructed in accordance with the details as shown on MMCD Drawing Numbers S1, S2, and S3. In cases where these details will not suffice, a detailed design drawing must be approved by the Approving Officer.

4.20 Cleanouts shall be installed at the end of all sanitary sewer lines.

## SECTION W - STANDARDS FOR ELECTRICAL, TELEPHONE, STREET LIGHTING, AND OTHER SERVICES SUPPLIED THROUGH WIRES

### W.1 GENERAL

- \*amended under bylaw 371, 2016*
- 1.1 Service Level 1 does not require underground wiring. Service Level 2 requires underground wiring and ornamental street lighting.

*\*amended under bylaw 371, 2016*

  - 1.2 Every parcel shall be provided with an adequate supply of electrical power, telephone communications, and television communications in accordance with the requirements of the appropriate utility company and the requirements of the regulatory bodies and approving agencies having jurisdiction.
  - 1.3 Transformers are to be located within the road right-of-way, in a location approved by the Approving Officer.

*\*amended under Bylaw 169, 2002*

  - 1.4 To preserve the rural character and minimize light pollution in the District of Highlands, generally, roadway lighting is not required. In certain instances, when directed by the Approving Officer for safety reason, all roadway light fixtures must provide fully shielded illuminations.
  - 1.5 Designs and plans shall be approved by the Approving Officer prior to construction.

*\*added under Bylaw 169, 2002*

  - 1.6 Lighting shall be designed by a Professional Lighting Engineer registered in the Province of BC, Roadway light levels shall be in accordance with a most recent edition of the "Guide for Design of Roadway Lighting" published by the Road and Traffic Association of Canada and construction shall be in accordance with the BC Electrical Code.

## W.2 STANDARDS FOR ROAD LIGHTING FOR SERVICE LEVEL 1

- 2.1 Street lighting for Service Level 1 shall be of cobra-head style with flat bottom tempered glass lens and mounted on BC Hydro Poles. They shall be installed only in those locations as directed by the Approving Officer. The pre-approved Manufacturers and Product for these luminaries are:

<b>WATTAGE</b>	<b>SUPPLIER</b>	<b>PHOTOMETRIC FILE</b>
150	T & B series 313 Cooper General Electric	AE45051.PHT OVFIS2D.IES 98081903.IES
250	T & B series 125 Cooper General Electric	P5820.IFS OVF2S2D.IES 1006.IES

## W.3 STANDARDS FOR ROAD LIGHTING FOR SERVICE LEVEL 2

### 3.1 SCOPE

*\*Deleted under Bylaw 169, 2002*

### 3.2 BASIC DESIGN CRITERIA - LIGHTING LEVELS

*\*Deleted under Bylaw 169, 2002*

### 3.3 TYPE OF LIGHTING

#### 3.3.1 Non-Ornamental Lighting

For Service Level 2 luminaries may be attached to power poles on roadways designated by the District of Highlands for overhead power lines, provided that davit arms of sufficient length are installed to bring the fixture to the edge of the travelled portion of the roadway.

#### 3.3.2 Ornamental Lighting

Ornamental lighting shall be provided on all roadways and walkways in Service Level 2. The type of standards, luminaries, lamps, underground wiring, etc., shall be as hereinafter specified.

### 3.4 ROAD LIGHTING STANDARDS FOR ORNAMENTAL LIGHTING

3.4.1 All standards shall be steel and of the type shown in the following table.

APPLICATION	TYPE	MINIMUM MOUNTING HEIGHT	MAXIMUM HEIGHT
Collector	Post top	5.5 m	6.5 m
Local Road	Post top	5.5 m	6.5 m
Country Road	Post top	5.5 m	6.5 m

NOTE: All standards situated within 9 metres of the travelled portion of a roadway shall be designed to shear under high impact.

3.4.2 All standards shall have heavy dipped galvanized finish.

3.4.3 All standards must be certified for wind loadings suitable to the exposure of the location, but not less than 160 kmph.

### 3.5 LUMINARIES

3.5.1 Luminaries shall be specially designed to accept the type and size of lamp proposed, and with a distribution pattern suited to the road width and location of the fixture. They shall be equipped with a closed refractor.

3.5.2 Luminaries and all electrical components must be C.S.A. approved.

3.5.3 Road luminaries shall be so placed and of distribution type to avoid excessive light pollution to residences. I.E.S. Type V distribution should only be used where no residences would be adversely affected.

*\*Amended under Bylaw 169, 2002*

3.5.4 Post top luminaries shall be one-piece die cast aluminium with integral pole top adapter, containing the ballast and photocell (where required) within the luminaire housing. The prismatic refractors shall be polycarbonate. The refractor shall be secured to the luminaire to totally seal the luminaire but allow movement if impacted. The luminaire shall have captive hinged lid and the lid shall be secured to the luminaire by metal rods, and not be supported by the refractor. Pre-approved luminaire is Lumec Transit Series VR702.

3.5.5 Davit mounted road luminaries to be smooth cast aluminium housing with prismatic polycarbonate refractor and one piece die formed alzak finished aluminium reflector. Luminaire should be natural aluminum finish, and have hinged housing for access to lamp and ballast. The photocell socket shall have adjustable twist lock receptacle and be sealed when not used. Pre-approved luminaire are as specified in item 2.1.

### 3.6 LAMPS

3.6.1 All lamps shall be high pressure sodium, having a minimum rated life of 20,000 hours.

3.6.2 The lamp sizes shall be 100, 150 or 250 watts and universal mounting.

### 3.7 BALLASTS

3.7.1 The ballasts shall be 120 volt supply and have 55V lamp voltage for 100 and 150 watt size, 100V lamp voltage for 250 watt size.

3.7.2 The ballasts shall be auto regulating type, with Class H insulation. The ballasts shall have push on connectors to simplify maintenance.

### 3.8 CONTROLS

3.8.1 Photocell control may be used to operate luminaries without contactors, but the maximum current carried by the photocell contacts shall not exceed 50% of the rated capacity.

3.8.2 Controls shall be provided on all road lighting. Use service base for davit type installation. For pole top luminaries, the controls may be contained within the pole, except the main disconnect shall be mounted externally and to the current Electrical Code.

3.8.3 Wiring from B.C. Hydro Service to main disconnects shall be run in raceway internal to the pole. The raceway within the pole shall be P.V.C. conduit or liquid tight flexible conduit.

3.8.4 Luminaries shall be controlled in groups, with H.O.A. control for inspection installed in poles or service bases at each main service point.

3.8.5 The main disconnects shall be secured to the pole with at least two 6.3mm self-tapping screws. The main disconnects shall be able to be locked off using a padlock. The main disconnects shall be enclosed in a gasketed weatherproof enclosure (EEMAC4). Any exposed fastening shall be the oval head tamperproof type.

3.8.6 Where less than 3 lights are involved in the system; where possible, the luminaries shall be connected to an existing adjacent luminaire controlled by an existing controller. If this is not possible then the luminaries shall have individual photo-electric controls.

### 3.9 UNDERGROUND WIRING

3.9.1 All ductwork and wiring shall be in accordance with the requirements of the B.C. Electrical Code. Not limiting the foregoing, the following are the District of Highlands minimum requirements:

- a) All underground wiring to be installed in P.V.C. conduits of a minimum of 25mm in size.
- b) All wiring to be copper, and insulation of RWU type.
- c) Utility warning tape 300mm over all underground conduit runs.

### 3.10 CONCRETE BASES

3.10.1 Concrete bases shall be provided for all ornamental light standards.

3.10.2 Bases shall not protrude more than 150mm above the finished grade of the adjacent ground, or less than 25mm.

3.10.3 Bases shall exceed the width of the luminaire base plate by a minimum of 25mm at all points around the base.

3.10.4 Concrete bases and bolt must be adequate to withstand the earlier noted wind loads, being installed in the ground to a minimum depth of 1.5m.

## SECTION WA - STANDARDS FOR WATER SERVICE AND FIRE PROTECTION

### WA.1 GENERAL

1.1 Service Level 1 requires that each lot shall have an individual well, constructed on the lot, for which the requirements of this Section have been met. Service Level 2 requires that prior to subdivision approval, each parcel shall be connected to a privately owned water utility, which has been granted a Certificate of Public Convenience and Necessity, met all requirements of the Comptroller of Water Rights and this Section and obtained the required permits and approvals from Island Health.

*Amended under Bylaw 393, 2017*

1.2 A Water Supply System serving more than one single-family residence will be required to obtain the required permits and approvals from Island Health. The well(s) that supply a Water Supply system are required to obtain a groundwater license through the BC Ministry of Forests, Lands and Natural Resources Operations.

- 1.3 Land within the Capital Regional District Urban Containment and Service Policy Area Boundary within the District of Highlands may be connected to the Greater Victoria Water Supply System. The Works shall be approved by the Capital Regional District in accordance with their current standards.

## WA.2 INDIVIDUAL WELLS FOR SERVICE LEVEL 1

- 2.1 Individual groundwater wells are required to meet the following requirements:

*Amended under Bylaw 393, 2017*

- a) A qualified professional (registered with the Association of Professional Engineers and Geoscientists of BC) with competency in hydrogeology, shall be responsible for the location, evaluation, design, and construction of the groundwater well. This qualified professional shall provide the hydrogeological report currently described in Section 2.1b.

*Amended under Bylaw 393, 2017*

- b) The qualified professional shall prepare, seal and submit a hydrogeological evaluation report that provides a professional opinion whether the groundwater well meets the bylaw requirements. This report shall include a site plan (to scale and including latitude and longitudinal coordinates) showing the location of the well site(s) including any unsuccessful test wells. The report should discuss, at a minimum, the hydrogeological setting of the well, aquifer boundaries, recharge conditions, the sustainable yield of the well, well water quality, and potential vulnerability of the well to contamination. The report shall include the results of all water quality and quantity testing undertaken as part of the testing program and address comments from other authorities reviewing the data, if provided.

*Amended under Bylaw 393, 2017*

- c) Wells shall be situated outside the area from possible sources of contamination, and outside the minimum setback distances identified in the BC Health hazards Regulation and the Sewerage System Regulations. Wells shall meet the minimum construction standards outlined in the BC Groundwater Protection Regulation. Well Construction Reports shall be submitted to the Comptroller of Water Rights, as per the requirements of the BC Groundwater Protection Regulation.

*Amended under Bylaw 393, 2017*

- d) The total sustainable yield of the well shall exceed 4000 litres per day (L/day). The groundwater source shall be capable of sustaining this rate of flow continuously without utilizing more than 70% of the available draw down below the lowest seasonal static groundwater level. A pumping test shall be designed and interpreted by the qualified professional, and carried out after the well is constructed and disinfected to determine if the well is capable of meeting the design demand of 4,000 L/day per lot served. The pumping test shall be conducted by a qualified well driller or well pump installer (registered with the BC Ministry of Environment) or a person

working under the direct supervision of a qualified professional, well driller or well pump installer and in accordance with the *Water Sustainability Act* and the guidelines outlined in the BC Ministry of Environment's Guide to Conducting Well Pumping Tests. The pumping test shall be conducted during the dry season when static groundwater levels are lowest (summer or early fall). The pumping test should consist of continuous pumping at a constant discharge rate of at least 4,000 L/day for a minimum duration of 72 hours and recovery level monitoring until the original static groundwater level is achieved.

*Amended under Bylaw 393, 2017*

- e) At least one sample of the pumped well water shall be taken near the end of the pumping test and sent to a laboratory for chemical analysis of the parameters required by the Vancouver Island Health Authority for Approval of New Sources. Including but not limited to turbidity, total dissolved solids (TDS), manganese, and bacteriological analysis (total coliform bacteria and *E.coli*) and other parameters if suspected of being present in the aquifer that could represent a health concern, be an indicator of aquifer health or help guide treatment, if required. The laboratory must be approved by the BC Provincial Health Officer to carry out the tests performed and reported on. The laboratory results for all samples shall be compared to the Guidelines for Canadian Drinking Water Quality and, if one or more parameters don't meet the requirements of the guidelines, the qualified professional shall provide an opinion on the potability of the water and recommendation for appropriate mitigation, if required.

*Added under Bylaw 393, 2017*

- f) Unused wells shall be either maintained as a monitoring well or decommissioned in accordance with the requirements of the BC Groundwater Protection Regulation. If converted to a monitoring well, the unused well shall be upgraded, as required, to meet the minimum construction requirements of the BC Groundwater Protection Regulation.

### WA.3 WATER SUPPLY FOR FIREFIGHTING IN SERVICE LEVEL 1

- 3.1 This standard identifies the minimum requirements in Service Level 1 for the provision of a water supply by the developer for fire fighting purposes.
- 3.2 All designs in this Section are to meet, as a minimum, the requirements of NFPA 299, "Protection of Life and Property from Wildfire", 1991, NFPA 1141, "Fire Protection in Planned Building Groups", 1990 and NFPA 1142, "Standard on Water Supplies for Suburban and Rural Fire Fighting", 1993.
- 3.3 Water supply for fire fighting shall come from a dry hydrant system, which may use cisterns. The details of this system are contained in Supplemental Detail Drawings FD-1, FD-1A, FD-2, FD-2A, and FD-3.

- 3.4 The location of these water supplies shall be such that the average travel time to supply fire-fighting water to buildings located in the proposed development is 5 minutes.
- 3.5 An all weather access road suitable for fire fighting vehicles is to be provided, with any required rights of way, to all dry hydrants and cisterns in the system.
- 3.6 The establishment of a minimum water supply for fire fighting in each development area requires the approval of the Approving Officer prior to the design of the water supply system for fire fighting. The Approving Officer may refer any design submission to the Insurers' Advisory Organization Inc. for its comments.
- 3.7 All designs require the approval of the Approving Officer prior to construction.

*\*amended under bylaw 371, 2016*

#### WA.4 WATER SUPPLY SYSTEMS IN SERVICE LEVEL 2

- 4.1 Each parcel in a Service Level 2 subdivision or development shall be serviced by a Water Supply System that meets the requirements of this section.
- 4.2 A Water Supply System serving water to more than one single-family residence will be required to obtain the necessary permits and approvals from Island Health.
- 4.3 If the source of supply for a Service Level 2 Water Supply System, operated as a water utility, is groundwater, then the supply shall meet all the requirements of Sub-section WA.2 of this Schedule except that the total developed dependable yield of the well shall exceed 4,000 litres per day per parcel to be serviced in the subdivision.
- 4.4 The Water Supply System shall provide each parcel with a water supply at the property line in sufficient pressure to meet the requirements of the B.C. Building Code and shall be shown to have sufficient pressure to meet the requirements of the B.C. Building Code for water pressure at the faucet at the highest point at which a plumbing fixture could be installed on the parcel having regards to bylaws and covenants applicable to the parcel. Individual home booster pumps are not acceptable.
- 4.5 Each parcel in a subdivision which is zoned for commercial, industrial, or institutional use shall be within 30 metres of a water main capable of supplying a minimum of 5000 litres per minute of water for four hours with a residual pressure of 138kPa.

- 4.6 The design of the Water Supply System shall be as per the “Design Guidelines for Rural Residential Community Water Systems” as published by the Ministry of Environment, and have obtained the required construction permits from Island Health, except that:
- a) The design maximum day demand per residential parcel shall be 5,300 litres;
  - b) All groundwater well sources are to be disinfected;
  - c) Water system storage capacity shall include a minimum of 140,000 litres for fire fighting in addition to storage for emergency and balancing usage;
  - d) Standpipes are not allowed; and
  - e) Fire hydrants are to meet the requirements of MMCD Specification 02666-2.6.
- 4.7 All Water Supply System design and construction shall be provided according to the criteria, standards, specifications and requirements of this Bylaw and its Schedules and the Master Municipal Construction Documents. Should any conflict exist between these documents, this Bylaw and its Schedules shall take precedence over the Master Municipal Construction Documents.
- 4.8 Construction and operation of a Water Supply System on District property and right of ways require permits and approvals from the District. These approvals shall be obtained before any construction of the Water Supply System commences.

## SECTION WT - STANDARDS FOR WALKWAYS AND TRAILS

### WT.1 GENERAL

- 1.1 Walkways and trails shall be provided and constructed where, in the opinion of the Approving Officer, they are needed to provide pedestrian access to schools, parks, playgrounds, open spaces, recreational areas, transportation, trail systems, beaches, and other community facilities, or for proper circulation of pedestrian traffic.
- 1.2 Where a walkway or trail is to be constructed in its own right-of-way the minimum width of the right-of-way shall be 5 metres.
- 1.3 Walkways shall be located adjacent to property lines within the highway right-of-way except as provided in item 4 below.
- 1.4 Walkways and trails are to meander where possible to avoid trees and natural features.

- 1.5 The grades of walkways and trails may vary where appropriate to provide improved connectivity with other walkways, parks, and trail systems.
- 1.6 Gravel shoulders are not permitted. The natural native landscaping shall be reinstated to the edge of the walkway, trail or landscaped area within the right-of-way.
- 1.7 Service Level 2 trails and walkways shall be asphalt or concrete surfaced. Service Level 1 walkways and trails shall be surfaced as per the direction of the Approving Officer.

## WT.2 OFF ROAD TRAIL STANDARDS

- 2.1 Off road trails shall be constructed by the developer in a right-of-way provided by the developer to the District of Highlands.
- 2.2 The entrance to parks or designated trail systems shall be identified with the appropriate Trail Marker and signage as approved by the Approving Officer.
- 2.3 Off road trails shall be constructed to the following requirements:
  - a) travelled trail width shall be 1.5 metres;
  - b) vegetation 0.5 metres on either side of the traveled trail is to be cleared of all overhanging limbs, all bush, and all brush to a height of 3.0 metres above the traveled trail;
  - c) unless otherwise directed by the Approving Officer, the traveled trail surface is to be constructed of compacted native soils with clean crushed gravel surfacing in the wet areas;
  - d) Hand constructed drainage works are to be provided by the developer along the trail as directed by the Approving Officer; and
  - e) The maximum sustained trail grade shall be 10%. Grades of up to 15% maximum will be permitted in sections less than 100 metres long provided that they constitute in total less than 20% of the trails provided by the developer.

## WT.3 ROADSIDE TRAIL (WALKWAY) STANDARDS

- 3.1 Walkways shall be constructed by the developer in road right-of-ways.
- 3.2 The entrance to parks or designated trail systems shall be identified with the appropriate Trail Marker and signage as approved by the Approving Officer.

3.3 Walkways shall be constructed to the following requirements:

- a) traveled walkway width shall be 1.5 metres;
- b) vegetation 0.5 metres on either side of the traveled walkway is to be cleared of all overhanging limbs, all bush, and all brush to a height of 3.0 metres above the traveled walkway;
- c) wherever possible existing vegetation between the walkway and the road shall be protected to act as a screen;
- d) unless otherwise directed by the Approving Officer, the traveled walkway surface is to be constructed of compacted native soils with clean crushed gravel surfacing in the wet areas;
- e) hand constructed drainage works are to be provided by the developer along the walkway as directed by the Approving Officer; and
- f) the maximum sustained walkway grade shall be 8%. Grades of up to 10% maximum will be permitted in sections less than 100 metres long provided that they constitute in total less than 20% of the trails and walkways provided by the developer.

SCHEDULE "C" OF THE SUBDIVISION OR  
DEVELOPMENT OF LAND BYLAW

SUPPLEMENTARY DETAIL DRAWINGS

CONSOLIDATED

## SCHEDULE "C"- SUPPLEMENTAL DETAIL DRAWINGS

The Supplemental Detail Drawings are supplemental to the Standard Detail Drawings of the Master Municipal Contract Documents (MMCD). The Supplementary Detail Drawings take precedence, in the case of conflict, over the Standard Detail Drawings of MMCD.

### INDEX

SDD 1	Drainage	Intensity Duration Curve
SDD 2	Drainage	Typical Ditch Cross-Section and Headwall
SDD 3	Roads	Typical Road Section – Service Level 1
SDD 4	Roads	Typical Road Section – Service Level 2
		<i>*Added under bylaw 334, 2012</i>
SDD5	Roads	Industrial Road Section
FD-1	Water	Small Cistern Plan
FD-1A	Water	Small Cistern Assembly
FD-2	Water	Large Cistern Plan
FD-2A	Water	Large Cistern Assembly
FD-3	Water	Dry Hydrant Detail

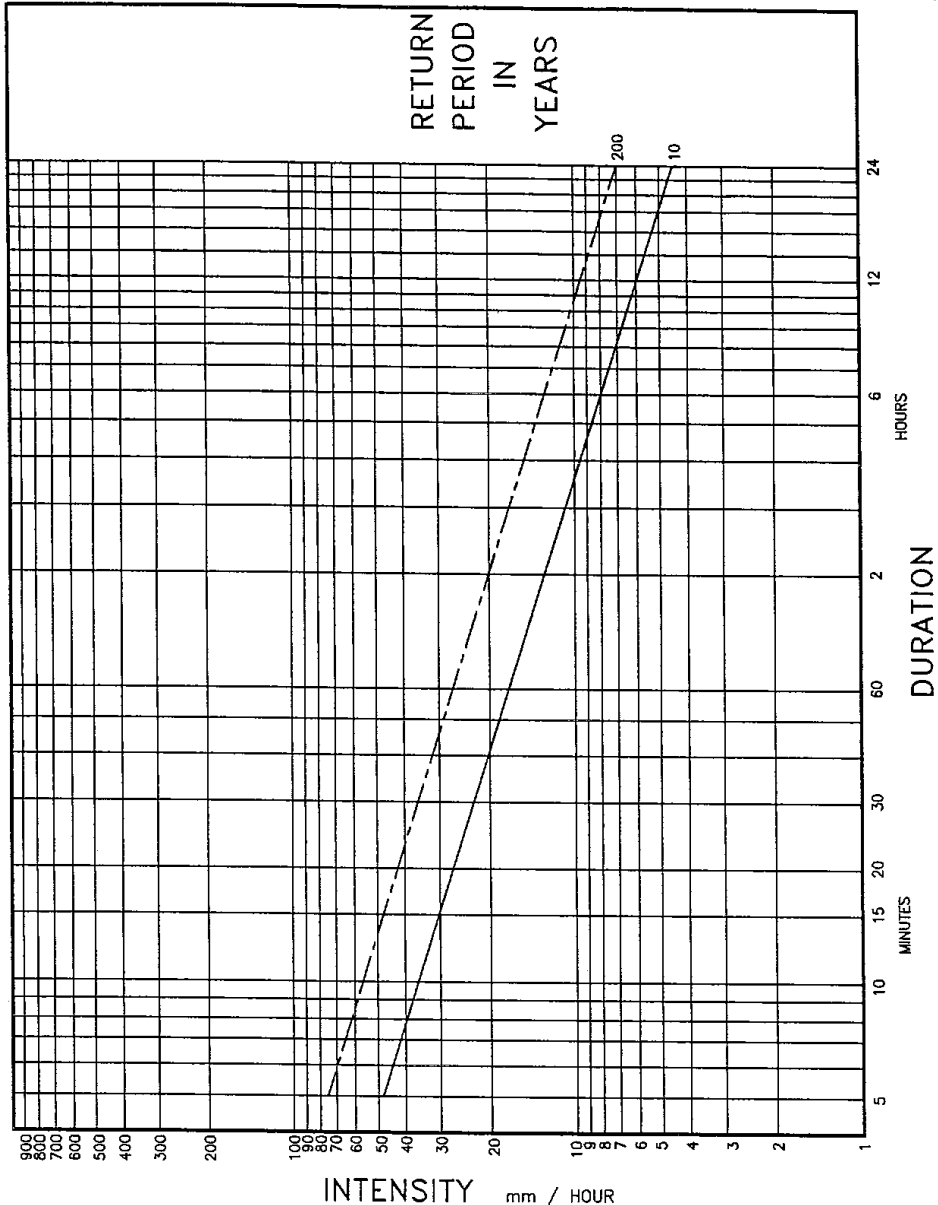

BASED ON VICTORIA - GONZALES RAINFALL DATA x 140% FOR THE PERIOD 1925 - 1986 (54 YEARS)  
 REFER TO SPECIFICATIONS FOR FURTHER DETAILS

INTENSITY DURATION CURVE

DISTRICT OF HIGHLANDS

DATE: DECEMBER 2000	SCALE:	DWG. No.
APPROVED BY: _____	FILE No.	SDD1

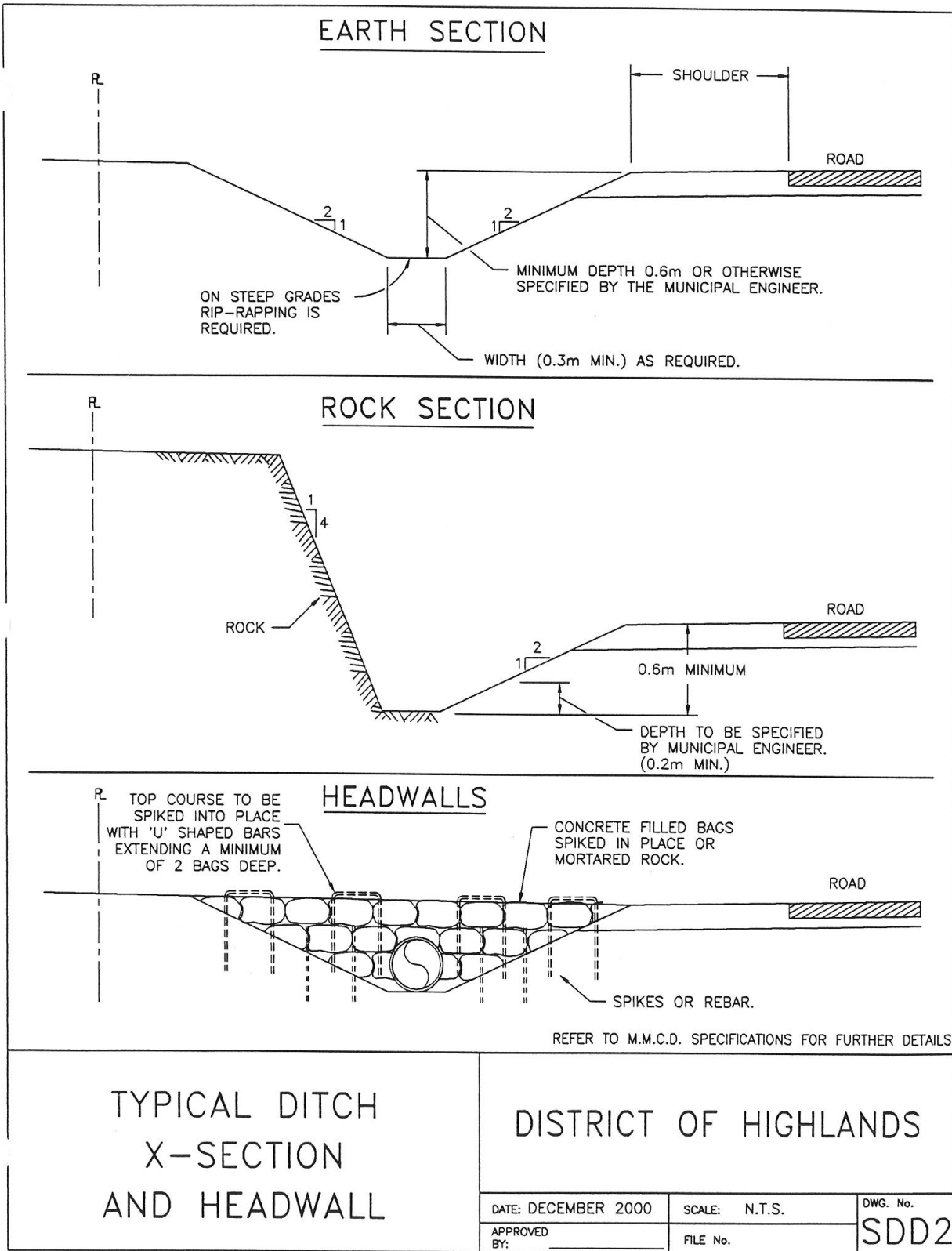

TYPICAL DITCH  
X-SECTION  
AND HEADWALL

DISTRICT OF HIGHLANDS

DATE: DECEMBER 2000

SCALE: N.T.S.

DWG. No.

APPROVED BY:

FILE No.

SDD2

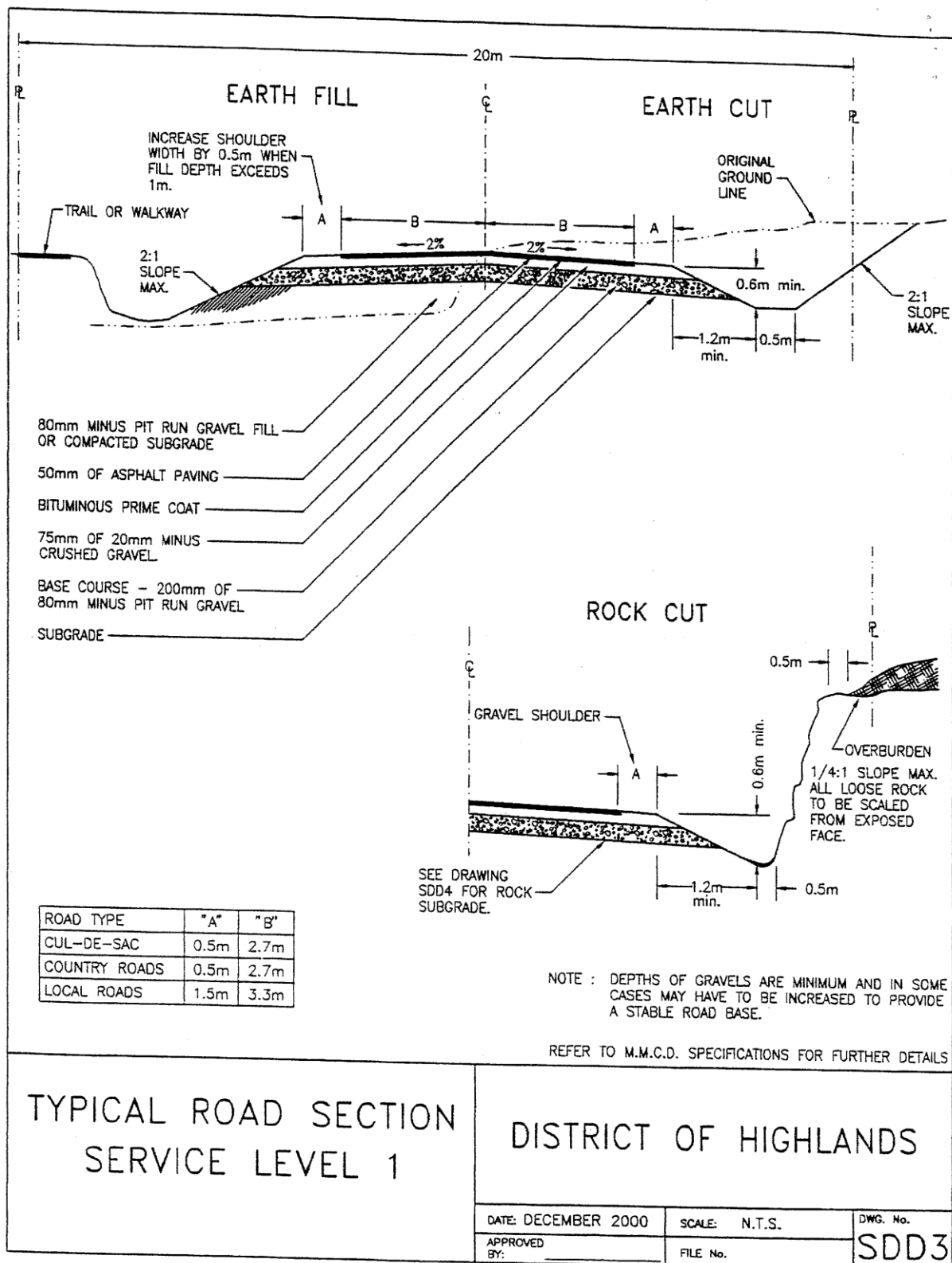

**Subdivision or Development of Land Bylaw No. 154, 2001 (Consolidated)**

This bylaw has been consolidated for convenience purposes only and may or may not contain the latest amendment (s). Electronic and on-line consolidated bylaws are not certified copies and they should not be used in place of actual district bylaws. If you require an accurate, up to date copy of the district bylaw, please contact the District Office.



SCHEDULE "A" TO BYLAW NO. 334

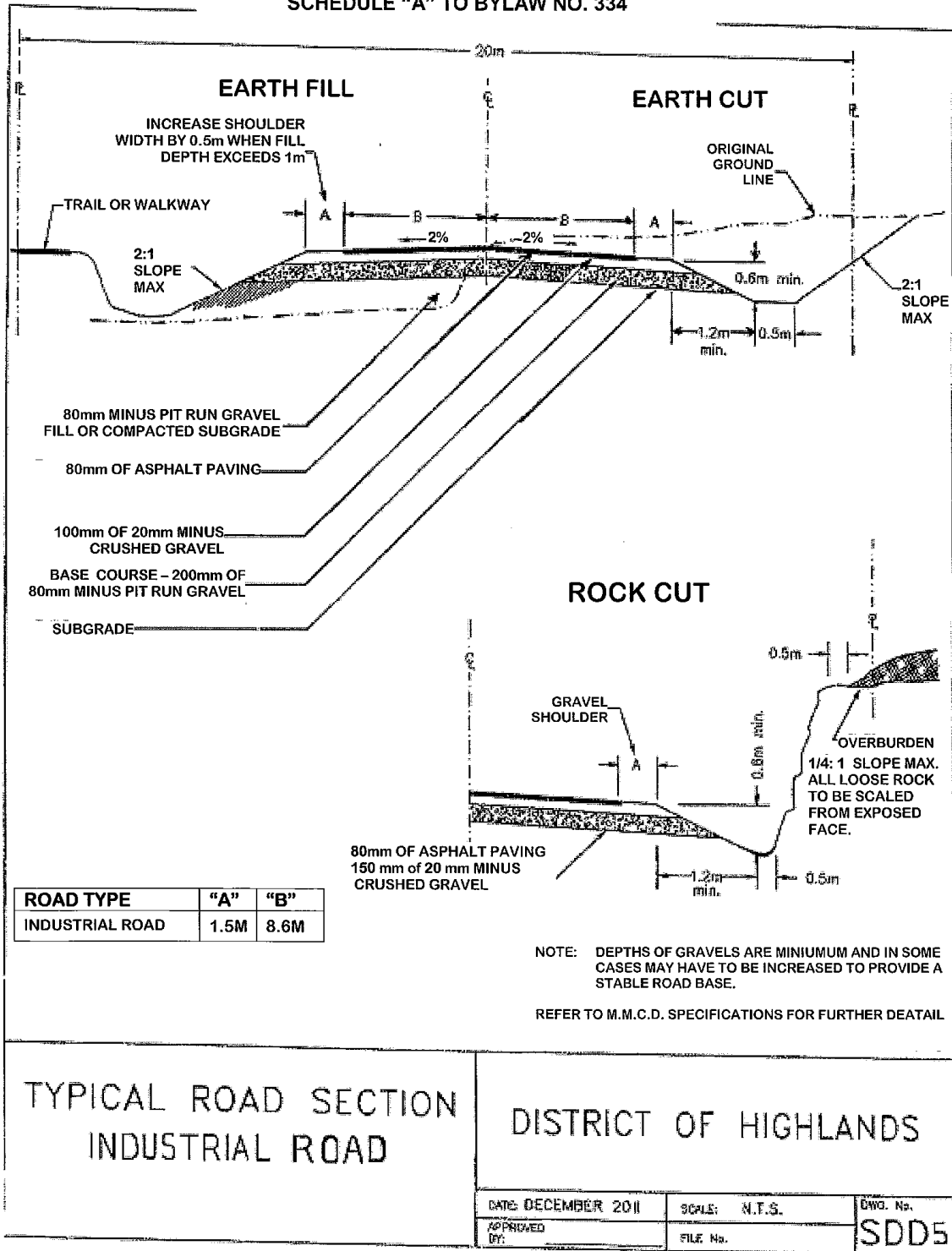

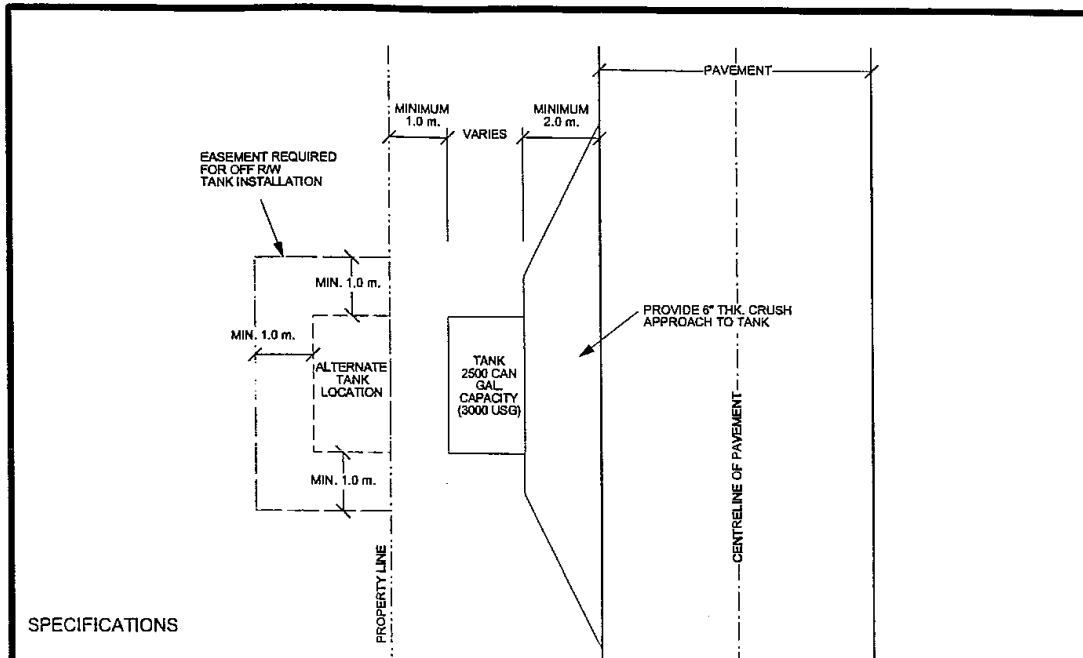

**SPECIFICATIONS**

1. If the building site is more than 1000 feet (305m) from a major water source (large cistern, dry hydrant, etc.), a small cistern is required. The cistern shall be sited between 50 and 100 feet (15 - 30m) from the building site.
2. The minimum cistern capacity must be 2,500 CAN (3000 US) gallons (11,350 L).
3. Prefabricated concrete storage tanks will be considered. The design of the cistern should be submitted to the Approving Officer or his designate for approval prior to construction. Plans should identify siting location.
4. Cast-in-place concrete must achieve a 28-day strength of 3000 psi (20,700 kpa). It must be placed with a minimum of 4-in. (10 cm) slump and vibrated to remove any voids.
5. Piping must be schedule 40 steel.
6. The initial suction connection must be 6 in. NST hose thread. The final connection must be 2 1/2 in. NST hose thread. It must be capped.
7. The entire cistern must be completed and inspected before any backfilling is done. Granular native backfill may be used and must be compacted in 12 in. (300mm) layers.

8. Bedding for the cistern must consist of a minimum thickness of 12 in of 3/4 to 1 1/2 inch pit run gravel, compacted to a minimum 95% standard proctor density.
9. Tankage must be designed so that the cistern will not float when empty.
10. After backfilling, top of tank must be protected by large rocks or bollards spaced to prevent entry from vehicles. Pumper truck must be able to park within 10 feet (3m) of suction connection.
11. Pitch of shoulder and vehicle pad from edge of pavement to pumper suction connection shall be from 1 to 6% grade.
12. Shoulder and vehicle pad must be of sufficient length to permit convenient access to suction component.
13. All horizontal suction piping should slope at 1% away from pumper connection.
14. Installer is responsible for completely filling cistern with water immediately after acceptance by municipality.

Revised: April 1, 2001 by MK

 <p><b>HIGHLANDS FIRE DEPT.</b></p>	<p><b>HIGHLANDS FIRE DEPT.</b> 1564 Millstream Road Victoria, B.C. V9E 1G6 E. Hall (250) 479-1814 * W. Hall (250) 474-2633 Fax (250) 474-3677</p>	<p><b>TITLE:</b> <b>FD-1 Water Storage Tank Detail SMALL CISTERN PLAN</b></p>
<p><b>DATE:</b></p>	<p>16 July 2000</p>	<p><b>SCALE:</b> NTS</p>
<p><b>DRAWN:</b></p>	<p>M. Kristiansen</p>	<p><b>APPROVED:</b></p>

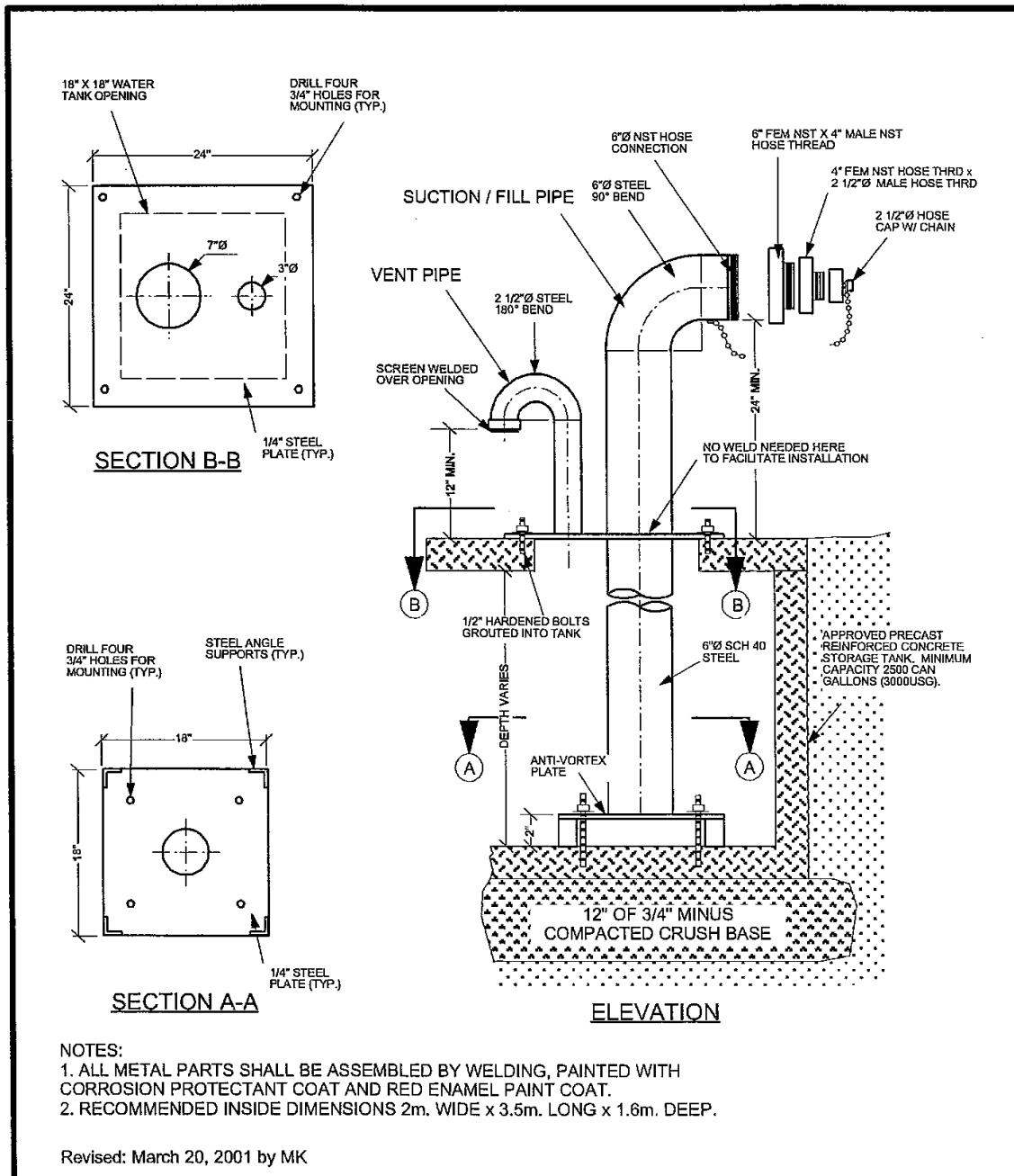

	<b>HIGHLANDS FIRE DEPT.</b> 1564 Millstream Road Victoria, B.C. V9E 1G6 E. Hall (250) 479-1814 * W. Hall (250) 474-2633 Fax (250) 474-3677	<b>TITLE:</b> <b>FD-1A</b> <b>Water Storage Tank Detail</b> <b>SMALL CISTERN ASSEMBLY</b>
	<b>DATE:</b> 16 July 2000	<b>SCALE:</b> 1:50
	<b>DRAWN:</b> M. Kristiansen	<b>APPROVED:</b>

**SPECIFICATIONS**

1. The large cisterns shall be located no more than 2000 feet (610m) from another approved large capacity water source (large cistern, dry hydrant, etc.).
2. The cistern capacity must be 25,000 CAN gallons (30,000USG) (113,500 L) minimum.
3. The suction piping system must be capable of delivering 1000 gpm (3800 L/min) for three quarters of the cistern capacity.
4. The design of the cistern must be submitted to the Approving Officer or his designate for approval prior to construction. All plans must be signed by a registered Professional Engineer. Plans should identify siting location.
5. The entire cistern shall be rated for highway loading, unless specifically exempted by the Municipality.
6. Cast-in-place concrete must achieve a 28-day strength of 3000 psi (20,700 kpa). It must be placed with a minimum of 4-in. (10.2 cm) slump and vibrated to eliminate any voids.
7. The concrete shall be mixed, placed and cured without the use of calcium chloride.
8. All concrete work shall follow the accepted practices of the latest edition of applicable CSA standards.
9. All suction, vent and fill piping shall be schedule 40 steel.
10. The initial suction connection must be 6 in. NST hose thread. The final connection must be 2 1/2 in. NST hose thread. The final connection must be capped.
11. Suction pipe connection shall be 20 - 24 in. (50 - 60 cm) above the level of the area where vehicle wheels will be located when cistern is in use.
12. Suction pipe must be supported either to top of tank or to a level below frost line.
13. Bottom of suction pipe to pumper connection must not exceed 12 ft. (3.6 m) vertical distance.
14. The filler pipe siamese shall have 2 1/2 in. (64 mm) National Standard female threads with plastic caps.
15. Filler pipe siamese shall be a minimum of 18 in. (45 cm) above final backfill grade.
16. The entire cistern must be completed and inspected before any backfilling is done.

17. All backfill material within 5 feet (1.5m) of tankage must be screened gravel with no stones larger than 1 1/2 in. (38 mm) and must be compacted in 12 inch (300mm) layers. Native backfill may be used outside of 5 feet and must be compacted in 18 inch (450mm) layers
18. Bedding for the cistern shall consist of a minimum thickness of 12 in of 3/4 to 1 1/2 inch pit run gravel, compacted to a minimum 95% standard proctor density.
19. Tankage must be designed so that the cistern will not float when empty.
20. Perimeter of tank at floor/wall joint must be sealed with 8 in. (20.3 cm) PVC waterstop or approved equal.
21. After backfilling, tank must be protected by concrete-filled 4 in. (100mm) diameter sch. 40 steel bollards or large rocks spaced at 6.5 feet (2.0 m) apart. Pumper truck must be able to park within 10 feet (3m) of suction pipe.
22. Depending on siting, the tank may have backfill over top. All backfill shall extend 10 ft (3.1 m) beyond the edge of the cistern, and then have a maximum 3:1 slope, loamed and seeded.
23. Pitch of shoulder and vehicle pad from edge of pavement to pumper suction connection shall be from 1 to 6% downhill grade.
24. Shoulder and vehicle pad should be of sufficient length to permit convenient access to suction component.
25. All horizontal suction piping shall slope at 1% away from pumper truck connection.
26. Installer is responsible for completely filling cistern upon acceptance by municipality.
27. Cistern shall have a lockable manway access, of a type approved by the Municipality, extending to the finished grade.
28. Cistern shall have 19mm galvanized iron rungs spaced at 12 inches (300 mm) on centre, grouted into the wall and extending from the access manway to the floor of the tank.

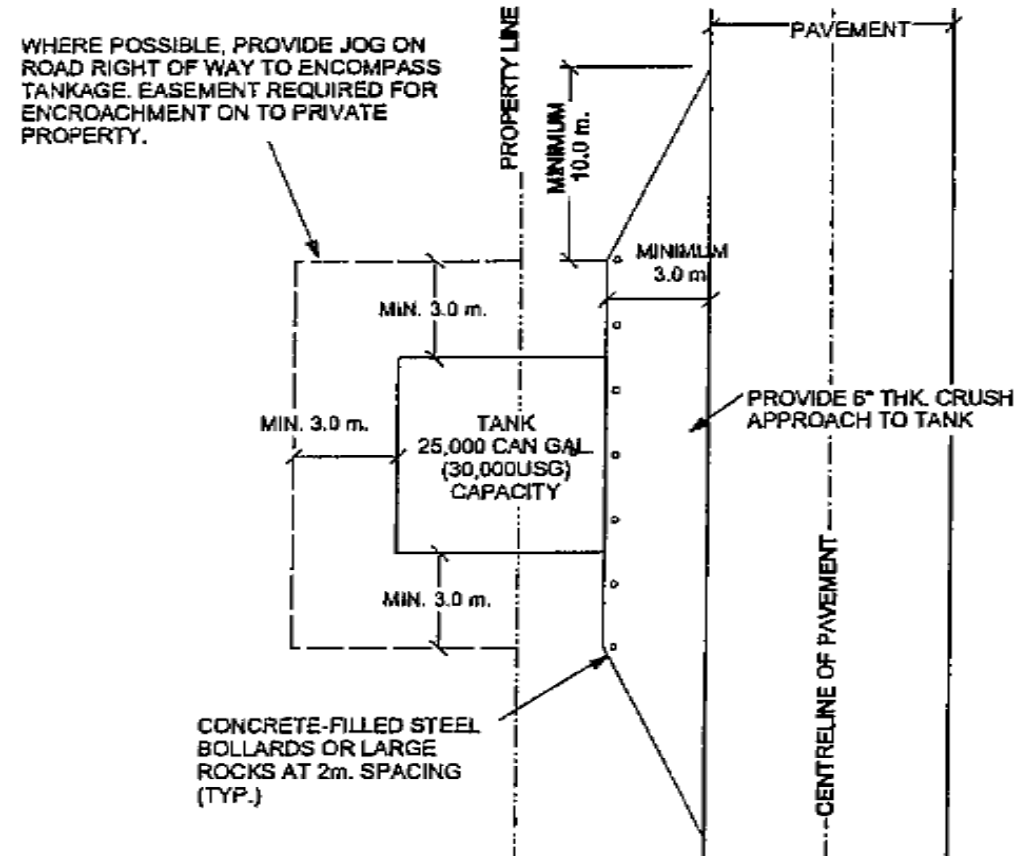

REVISIONS	 <b>HIGHLANDS FIRE DEPT.</b> 1564 Millstream Road Victoria, B.C. V9E 1G6 E. Hall (250) 479-1814 * W. Hall (250) 474-2533 Fax: (250) 474-3677	TITLE:	<b>FD-2 Water Storage Tank Detail LARGE CISTERN PLAN</b>		
March 4, 2001 by MK		DATE:	16 July 2000		
March 20, 2001 by MK		DRAWN:	M. Kristiansen	SCALE:	1:50
April 1, 2001 by MK				APPROVED:	

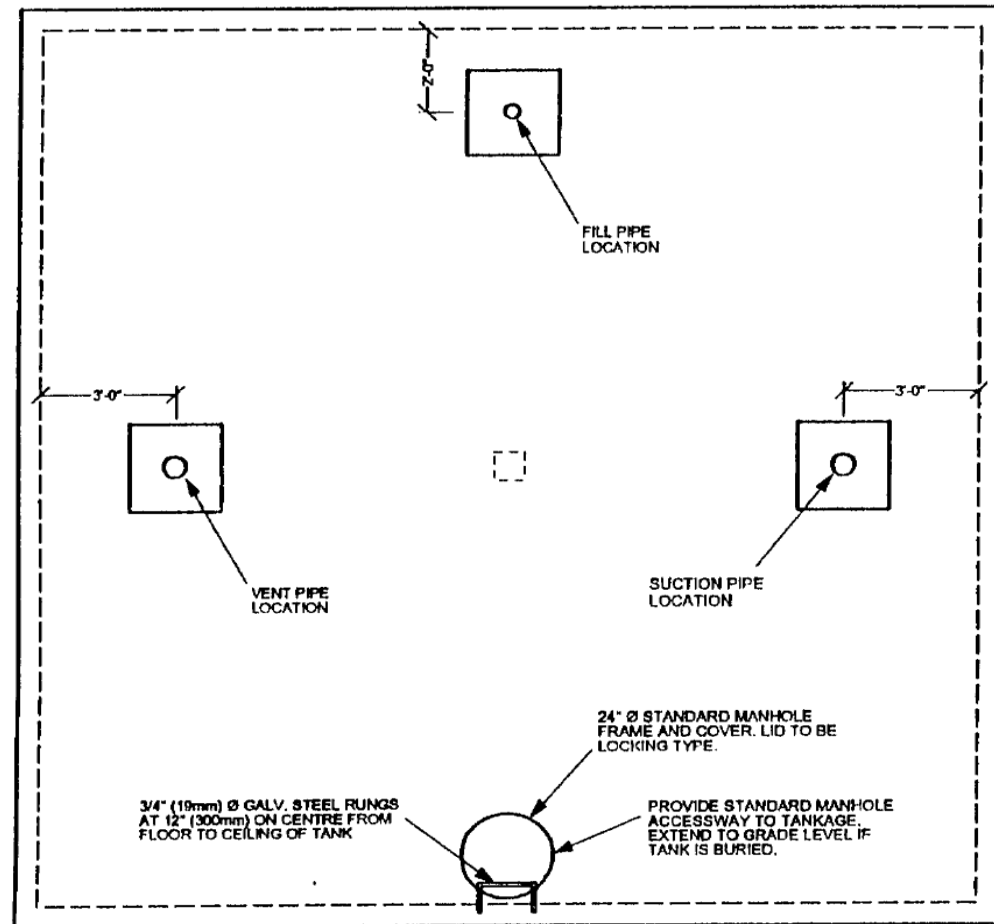

TOP VIEW  
SCALE 1:50

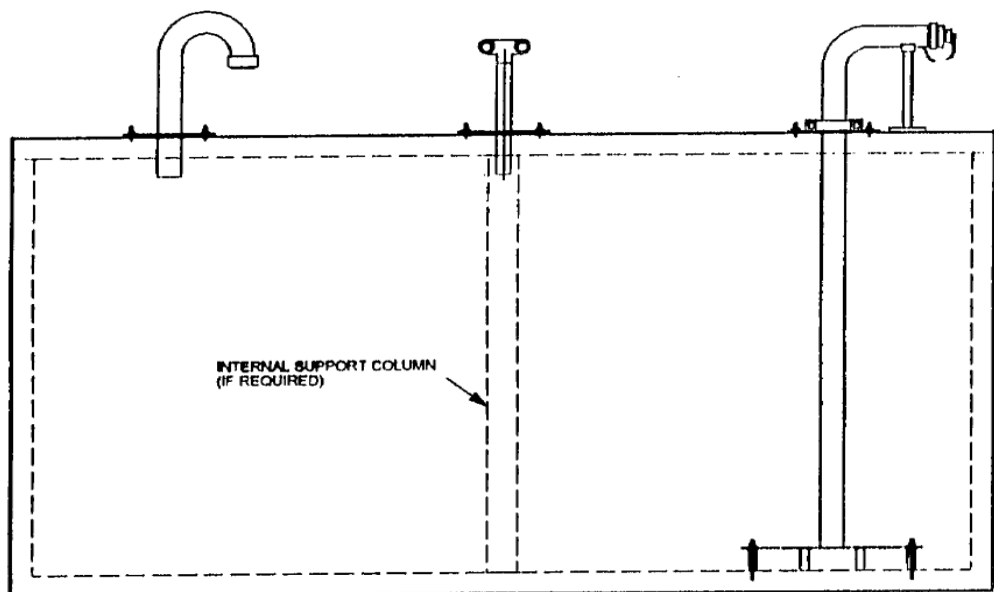

SIDE VIEW  
SCALE 1:50

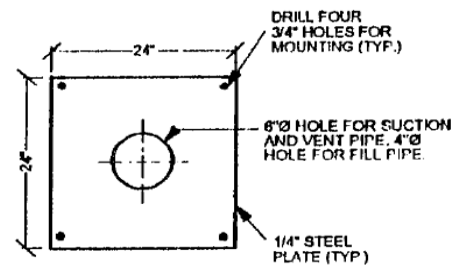

SUCTION, FILL AND VENT PIPES  
SCALE 1:25

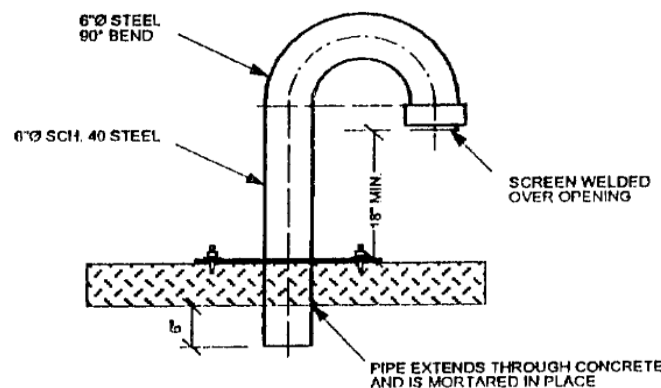

VENT PIPE DETAIL  
SCALE 1:25

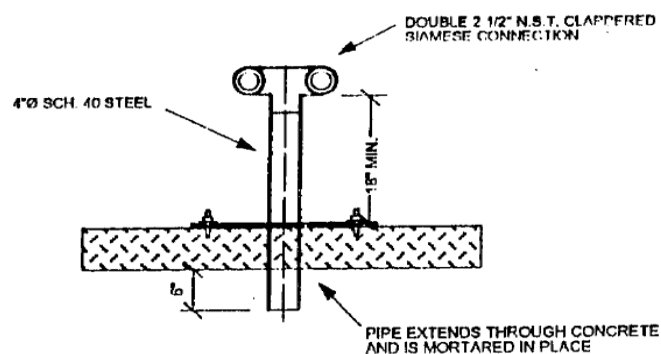

FILL PIPE DETAIL  
SCALE 1:25

NOTES:  
1. ALL METAL PIPING COMPONENTS SHALL BE ASSEMBLED BY WELDING, PAINTED WITH CORROSION PROTECTANT COAT AND RED ENAMEL PAINT COAT.  
2. RECOMMENDED INSIDE DIMENSIONS 20.5 FT. (6.25m) WIDE x 20.5 FT. (6.25m) LONG x 9.85 FT. (3.0m) DEEP.

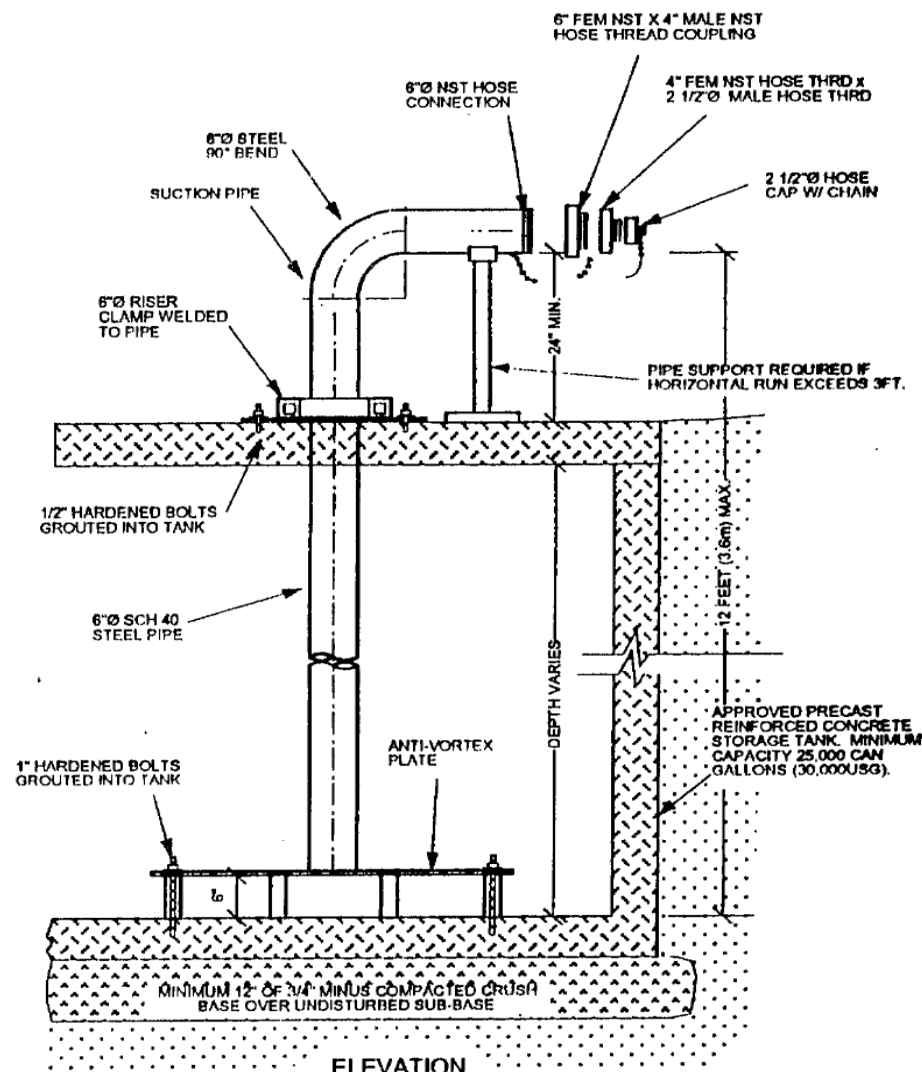

ELEVATION

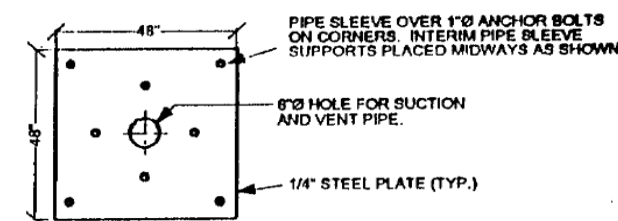

ANTI-VORTEX PLATE PLAN  
SCALE 1:50

REVISED: MARCH 20, 2001 by MK  
REVISED: MARCH 4, 2001 by MK

	<b>HIGHLANDS FIRE DEPT.</b> 1564 Millstream Road Victoria, B.C. V9E 1G6 E. Hall (250) 479-1814 • W. Hall (250) 474-2813 Fax (250) 474-3077	TITLE: <b>FD-2A          Water Storage Tank Detail          LARGE CISTERN ASSEMBLY</b>
	DATE: 16 July 2000 DRAWN: M. Kristiansen	SCALE: AS SHOWN APPROVED:

**SPECIFICATIONS**

1. APPLICANT SHALL SUBMIT PLAN SHOWING INTENDED LOCATION OF DRY HYDRANT FOR APPROVAL PRIOR TO BEGINNING CONSTRUCTION.
2. APPLICANT SHALL INCLUDE THE FOLLOWING INFORMATION WITH HIS SUBMITTAL:
  - a. INTAKE SCREEN LENGTH -
  - b. LATERAL (HORIZONTAL) RUN LENGTH -
  - c. RISER HEIGHT -
  - d. TOTAL STRAIGHT PIPE LENGTH -
  - e. NO. OF BENDS
3. ALL EXPOSED PVC AND ALL STEEL PIPING SHOULD BE PRIMED AND PAINTED WITH APPROPRIATE PAINT TO PREVENT DETERIORATION. PAINT COLOR SHOULD BE RED.
4. A MINIMUM NUMBER OF BENDS, PREFERABLY TWO, SHOULD BE USED IN THE SYSTEM. 90 DEGREE BENDS SHALL BE LONG SWEEP TYPE OR COMBINATION 45 DEGREE BENDS.
5. INSTALL CONCRETE THRUST BLOCK AT ALL UNDERGROUND BENDS.

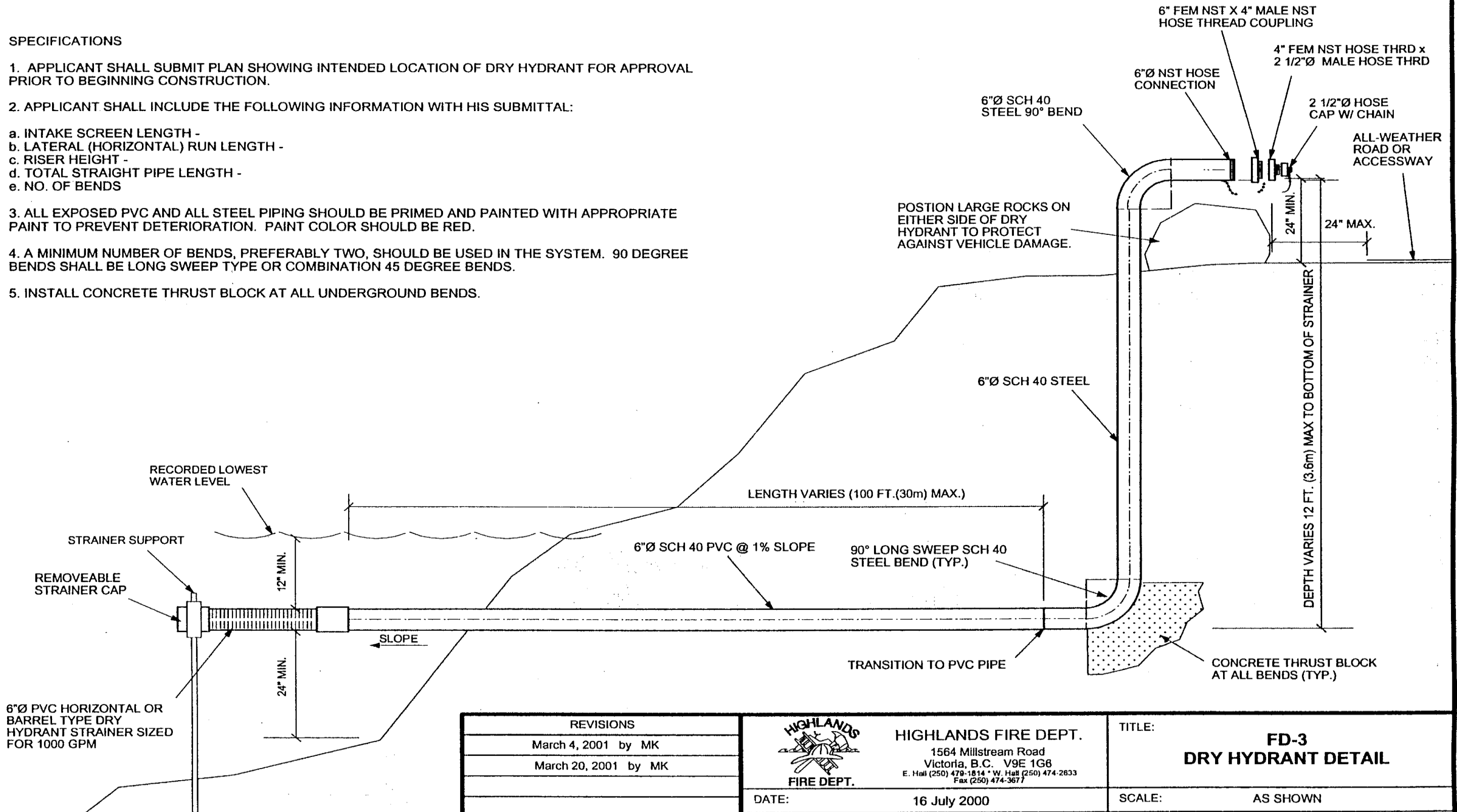

REVISIONS
March 4, 2001 by MK
March 20, 2001 by MK

 <p><b>HIGHLANDS FIRE DEPT.</b></p>	<p><b>HIGHLANDS FIRE DEPT.</b>                  1564 Millstream Road                  Victoria, B.C. V9E 1G8                  E. Hall (250) 479-1814 * W. Hall (250) 474-2633                  Fax (250) 474-3677</p>
	<p>DATE: 16 July 2000</p> <p>DRAWN: M. Kristiansen</p>

TITLE:	<b>FD-3 DRY HYDRANT DETAIL</b>
SCALE:	AS SHOWN
APPROVED:	

SCHEDULE "D" OF THE SUBDIVISION OR  
DEVELOPMENT OF LAND BYLAW

STANDARD FORMS

SCHEDULE "D"- STANDARD FORMS AND  
CERTIFICATES

TABLE OF CONTENTS

<b>FORM</b>	<b>TITLE</b>
F-01	Application for Preliminary Layout Assessment
F-02	Application for Design Drawing Assessment
F-03	Application for Subdivision Approval
F-04	Engineer's Undertaking
F-05	Drainage Certificate
F-06	Permission to Construct
F-07	Private Well Certification
F-08	Well Pump – Field Test
F-09	Well Pump – Test Summary
F-10	Certificate of Inspection
F-11	Agreement to pay Non-refundable Deposit
F-12	Agreement for Construction of Subdivision Services



**PRELIMINARY LAYOUT ASSESSMENT APPLICATION**

Applicant File Number		District of Highlands File Number			
A. PROPOSAL – This is an application for preliminary layout assessment for all properties involved					
Subdivision Type		<input type="checkbox"/> Fee Simple <input type="checkbox"/> Sec. 946. Local Government Act <input type="checkbox"/> Bare Land Strata			
		<input type="checkbox"/> Other (specify)			
Full Legal Description as per State of Title Certificate(s)					
Full Civic Address					
Property Location	Kilometers	North	South	East	From
					West
	Access Road			Property Zoning	
	Existing Land Use			Intended Land Use	
Surrounding Land Use					
	North	South	East	West	
Proposed Sewage Disposal	Septic Tank	Community System	Other (specify)	Number of Lots	
Proposed Water Supply	Individual Well	Community System	Other (specify)		
Water Licenses (attach)					

**B. APPLICATION INFORMATION**

All of the following information is required in order to begin processing your application:

1. I have enclosed:
  - a current State of Title Certificate for each property;
  - copies of all charges indicated on the title (restrictive covenants, easements, etc);
  - a current BC Assessment Authority Novice showing property tax classification;

Ten copies of a sketch plan drawn to scale and showing the following information:

- all proposed lots, remainders and roads in relation to adjacent properties, extending at least beyond the far edge of each adjacent property
- all pertinent dimensions, existing road names, north arrow and perimeter of the proposed subdivision

- the accurate location and outline of all existing buildings and indicate which will remain after subdivision
- the nature, location and dimensions of any restrictive covenant, easement or right-of-way affecting the proposed subdivision
- the accurate locations of wells, sewage disposal facilities, percolation test holes and soil inspection holes, water lines, sewage lines, hydro/telephone lines, driveways
- the accurate location of all lakes, river, ponds and drainage courses that shows the natural boundary of each
- a contour plan of the subdivision area if any of the terrain slopes more than 10% (do not use average slope to determine if a contour plan must be supplied)

2. Under section 26.1 of the Waste Management Act, a person who knows or reasonably should know that a site has been used or is used for industrial or commercial purposes or activities must in certain circumstances provide a site profile (site profile attached). FORM F-01 (page 1 of 2)

Schedule 2 of the Contaminated Site Regulations sets out the types of industrial or commercial purposes or activities to which site profile requirements apply. (Schedule 2 attached).

3. I have flagged the corners of the property, the proposed lot lines, the proposed roads and the percolation test holes.

4. Is the property location within the Agricultural Land Reserve? YES NO

5. Is the property located within the Forest Land Reserve? YES NO

6. I have indicated in Section C:

- if the property is subject to any natural hazards (i.e. land slide, rock fall, erosion, flooding, avalanche);
- if the subdivision is for a relative (i.e. Section 946 Local Government Act).

C. FURTHER INFORMATION AND COMMENTS (attach a separate sheet if more space is required)

---



---



---



---



---

D. OWNER(S) / APPLICANT INFORMATION

---

Property Owner(s) Full Name(s) Home Telephone

---

Address Business Telephone

---

Cell phone Fax

---

Agent Full Name Home Telephone

---

Address Business Telephone

---

Cell phone Fax

I certify that all the information above and on all plans and other attachments is true, correct and complete. I understand that this submission constitutes a preliminary application only.

---

Owner/Authorizing Agent Signature Date Applicant/Agent Signature Date

The personal information on this form is collected under the authority of the Land Title Act. The information collected will be used to process your preliminary layout assessment application. If you have any questions about the collection, use and disclose of this information, contact the District of Highlands.

Incomplete applications will not be processed. All further correspondence regarding this application must quote the legal description of the lot or the file number

FORM F-01 (page 2 of 2)



## DEVELOPMENT APPLICATION SIGNS

### REZONING/ OCP AMENDMENT and SUBDIVISION

A proponent of a rezoning application and subdivision application will be required to post a sign on the land that is the subject of the application, to advertise the proposed development or subdivision.

1. The sign shall be posted not less than five days prior to consideration by the Advisory Planning Commission, Select Committee, Committee of the Whole, or Council, as the case may be.
2. In the case of subdivision application, the applicant will be asked to post the sign within one week of the subdivision approving officer receiving the application.
3. The sign shall remain posted until:
  - i. in case of rezoning application, after the public hearing; and
  - ii. in case of subdivision application, after final approval of subdivision.
4. Signs are to be easily visible from a vehicle and posted on the shoulder of each road fronting the property that is subject to the application.
5. The applicant shall deposit with the District \$50.00 for each sign, of which \$30.00 shall be returned to the applicant upon return of the sign in good condition.
6. The applicant shall maintain the sign(s) in good order and will undertake to return them to the District upon completion of the application.

---

File No. \_\_\_\_\_

Receipt No. \_\_\_\_\_

Type of Application:

\_\_\_\_\_ Rezoning/ OCP Amendment

\_\_\_\_\_ Subdivision

This Declaration confirms that I have received \_ sign (s) giving notice of this application.

Date: \_\_\_\_\_

\_\_\_\_\_  
Signature of Applicant

---

Date Returned: \_\_\_\_\_

Eligible Refund: \_\_\_\_\_

\_\_\_\_\_  
Signature of Official



District of Highlands  
1980 Millstream Road  
Victoria, BC V9B 6H1

### DESIGN DRAWING ASSESSMENT APPLICATION

To: District of Highlands Date: \_\_\_\_\_

Attention: Approving Officer Highlands File No.: \_\_\_\_\_

We / I \_\_\_\_\_ confirm that we / I have been  
(Developer's Engineer)

retained by \_\_\_\_\_ for the subdivision of  
(Developer)

\_\_\_\_\_  
(Legal description of properties)

To carry out the preparation of detailed design drawings in full compliance with the "Subdivision or Development of Land Bylaw No. 154, 2001". This is an application for an assessment of the attached design drawings; the number, and the nature of which are specified in Section G.11 of Schedule B of the Bylaw.

DEVELOPER'S ENGINEER:

Signature: \_\_\_\_\_

Name: \_\_\_\_\_

Company: \_\_\_\_\_

ENGINEER'S SEAL

Address: \_\_\_\_\_

FORM F-02



District of Highlands  
1980 Millstream Road  
Victoria, BC V9B 6H1

## APPLICATION FOR SUBDIVISION APPROVAL

To: District of Highlands Highlands File No.:

Attention: Approving Officer

We / I \_\_\_\_\_ certify that we / I have met all the (Owner/Authorizing Agent)

requirements for the subdivision of \_\_\_\_\_ (Legal Description of properties)

And hereby apply for subdivision approval.

Attached are:

- Completed Schedule "D" forms F-07, F-08, F-09 and F-10 complete with all required supporting documentation;
- The subdivision plan complete with all required copies ready for signature by the District of Highlands;
- All rights-of-way, easement, restrictive covenants, and similar documents required for registration on title; and
- All other documentation previously requested by the Approving Officer.

Owner / Applicant:

Signature: \_\_\_\_\_

Name: \_\_\_\_\_

Company: \_\_\_\_\_

Address: \_\_\_\_\_

Date: \_\_\_\_\_

FORM F-03



District of Highlands  
1980 Millstream Road  
Victoria, BC V9B 6H1

### ENGINEER'S UNDERTAKING

To: District of Highlands Date: \_\_\_\_\_

Attention: Approving Officer Highlands File No.: \_\_\_\_\_

We / I \_\_\_\_\_ confirm that we / I have been  
(Developer's Engineer)

retained by \_\_\_\_\_ for the subdivision of  
(Developer)

\_\_\_\_\_  
(Legal Description of properties)

To carry out construction survey, required design revisions, construction inspections, project supervisions, field co-ordination, preparation of as-built drawings and certification of as-built drawings within 60 days of substantial completion inspection. The professional services provided during construction will assure that all construction is in substantial compliance with the accepted design drawings prepared by:

\_\_\_\_\_ and dated \_\_\_\_\_  
(Design Engineer)

and in full compliance with "Subdivision or Development of Land Bylaw No. 154, 2001". We / I will also undertake quality management services on the subject project as required by the Engineers and Geoscientists Act Code of Ethics Section 14a.

#### DEVELOPER'S ENGINEER:

Signature: \_\_\_\_\_

Name: \_\_\_\_\_

Company: \_\_\_\_\_

Address: \_\_\_\_\_

ENGINEER'S SEAL

FORM F-04



District of Highlands  
1980 Millstream Road  
Victoria, BC V9B 6H1

## DRAINAGE CERTIFICATE

Developer: \_\_\_\_\_

Highlands File No.: \_\_\_\_\_

Pursuant to Section D of Schedule "B" of the Subdivision and Development of Land Bylaw:

I hereby certify that downstream drainage facilities for a distance of 3km have been checked with respect to line, grade and size, and that the downstream facilities are capable of handling the projected increase in drainage created by this project, without causing any adverse effect to District or private property.

### PROPERTY ENGINEER RESPONSIBLE FOR DESIGN:

Signature: \_\_\_\_\_

Name: \_\_\_\_\_

Company: \_\_\_\_\_

Address: \_\_\_\_\_

\_\_\_\_\_

\_\_\_\_\_

Date: \_\_\_\_\_

ENGINEER'S SEAL:

FORM F-05



District of Highlands  
1980 Millstream Road  
Victoria, BC V9B 6H1

PERMISSION TO CONSTRUCT

Highlands File No.: \_\_\_\_\_

Authorization to proceed with construction is hereby granted to:

NAME OF DEVELOPER: \_\_\_\_\_

ADDRESS: \_\_\_\_\_

For the works described generally as: \_\_\_\_\_  
\_\_\_\_\_  
\_\_\_\_\_

Authorized Start Date: \_\_\_\_\_ Completion Date: \_\_\_\_\_

Authorized House of Work: From \_\_\_\_\_ hours to \_\_\_\_\_ hours  
Monday to Saturday inclusive.

Check the following:

- |       |                                    |
|-------|------------------------------------|
| _____ | Construction plans approved        |
| _____ | Certificates of insurance received |
| _____ | Administration fee paid            |
| _____ | Security deposit paid              |
| _____ | Servicing Agreement completed.     |

Agreement Number: \_\_\_\_\_

Developer's Engineer: \_\_\_\_\_

Contact: \_\_\_\_\_

Bus Tel: \_\_\_\_\_

Cell Tel: \_\_\_\_\_

Special Conditions:

\_\_\_\_\_  
\_\_\_\_\_  
\_\_\_\_\_

\_\_\_\_\_  
Approving Officer's Signature

\_\_\_\_\_  
Date

c: Contractor

FORM F-06



## PRIVATE WELL CERTIFICATION

Pursuant to Section WA of Schedule “B” of the Subdivision or Development of Land Bylaw, which requires that each lot to be created and/or each existing lot forming part of the proposed development can be serviced with potable water in accordance with requirements of the Bylaw for the development of:

LEGAL DESCRIPTION: \_\_\_\_\_

HIGHLANDS FILE NO: \_\_\_\_\_

I certify that a quality of not less than 4,000 litres per day has been proven for each existing or proposed lot in the development.

I certify that each well within the subdivision has been tested and is capable of continuously providing water for each existing or proposed lot in the development at a rate of 9 litres per minute for a four-hour period.

I certify that water quality tests have been conducted and that the “Canadian Drinking Water Standards, latest edition” can be met for each existing or proposed lot in the development.

Professional Engineer responsible for test:

Signature: \_\_\_\_\_

Name: \_\_\_\_\_

Company: \_\_\_\_\_

Address: \_\_\_\_\_

\_\_\_\_\_

Date: \_\_\_\_\_

ENGINEER’S SEAL

Form F-07 shall be submitted with completed sets of Forms F-08 and F-09 for each well as required pursuant to Section WA of Schedule “B”.

FORM F-07





## WELL PUMP – TEST SUMMARY

OWNER'S NAME: \_\_\_\_\_

DATE: \_\_\_\_\_

HIGHLANDS FILE NO.: \_\_\_\_\_

WELL NO.: \_\_\_\_\_

LOCATION: \_\_\_\_\_  
(UTM coord And description)

TEST NO.: \_\_\_\_\_

SHEET: \_\_\_\_\_ of \_\_\_\_\_

Well Completion Date	Screen Design (mark one)	Description of Aquifer
Depth _____ m	<input type="checkbox"/> Open Hole <input type="checkbox"/> Slotted Casing _____	
Diameter _____ mm	<input type="checkbox"/> Screen <input type="checkbox"/> Gravel Pack _____	
Static Water Level _____ m	<input type="checkbox"/> Other _____	Screen interval _____ m to _____ m

### Pump Test

Start: Date (d/m/y) \_\_\_\_\_ Time (h:m) \_\_\_\_\_

Pump Type  Elect submersible  Jet  Air lift  
 Other (describe): \_\_\_\_\_

Test pump set at \_\_\_\_\_ m below ground

Water level sounded by:  Electric tape  Air bubbler  Steel tape  
 Other (describe): \_\_\_\_\_

Flow measured by:  Container & Watch  Flow meter  Orifice & tube  
 Other (describe): \_\_\_\_\_

### Test

Initial non-pumping level \_\_\_\_\_ m  
Constant rate of yield \_\_\_\_\_ lpm  
Test duration \_\_\_\_\_ h  
Drawdown at end of test \_\_\_\_\_ m  
Recommended pumping rate \_\_\_\_\_ lpm

### Water Samples Taken During Test

Chemical Analysis  Yes  No  
Bacterial Analysis  Yes  No  
Water Temperature \_\_\_\_\_ °C  
Any particular gas smells noted

Comments on clarity of water  
\_\_\_\_\_  
\_\_\_\_\_

Other comments:  
\_\_\_\_\_  
\_\_\_\_\_  
\_\_\_\_\_

FORM F-09



## CERTIFICATION OF INSPECTION

I hereby certify that all engineering and construction services required under the Subdivision and Development of Land Bylaw of the District of Highlands for the subdivision of :

LEGAL DESCRIPTION: \_\_\_\_\_

HIGHLANDS FILE NO.: \_\_\_\_\_

Which services were approved for construction under drawing numbers:

DRAWING NO.	DATE	DRAWING NO.	DATE

have been inspected by or under the direction of:

\_\_\_\_\_

I further certify that the "Record (as-built) Drawings" hereby submitted represent the works and services as installed for the aforementioned subdivision. These works and services were installed with sufficient inspection to assure construction in substantial compliance with approved design drawings, in full compliance with the Highlands Subdivision or Development of Land Bylaw and as required by the Engineer and Geoscientist Act Code of Ethics.

Professional Engineer responsible for design:

Signature: \_\_\_\_\_

Name: \_\_\_\_\_

Company: \_\_\_\_\_

Address: \_\_\_\_\_

\_\_\_\_\_

Date: \_\_\_\_\_

Engineer's Seal

FORM F-10



AGREEMENT TO PAY
NON-REFUNDABLE DEPOSIT

I, Name: \_\_\_\_\_

Address: \_\_\_\_\_

Agree to pay the amount of \$ \_\_\_\_\_ as a non-refundable deposit towards the installation described as:

\_\_\_\_\_
\_\_\_\_\_

This payment is made pursuant to clause 12 of the Subdivision or Development of Land Bylaw and is made in lieu of construction of the Works and Services as itemized on the attached form identified as "Estimates of Non-Refundable Deposit".

This payment is made as full compensation for the itemized works and services and fulfills all the requirements of the Subdivision or Development of Land Bylaw.

FOR CORPORATE BODY SIGNED, SEALED AND DATED THIS Day of 20 The Corporate Seal of was hereunto affixed in the presence of: Signature: Title: seal
FOR PRIVATE INDIVIDUAL SIGNED, SEALED AND DATED THIS Day of 20 by the above named in the presence of (witness): Signature: Name: Address: Owner's Signature
FOR THE CORPORATION OF THE DISTRICT OF HIGHLANDS SIGNED, SEALED AND DATED THIS Day of 20 The Corporation Seal of the District of Highlands was hereunto affixed in the presence of: MAYOR: CLERK: seal



AGREEMENT FOR CONSTRUCTION OF SUBDIVISION SERVICES

THIS AGREEMENT made the \_\_\_\_\_ day of \_\_\_\_\_, 20\_\_\_\_\_.

BETWEEN:

District of Highlands  
1980 Millstream  
Road Victoria,  
British Columbia.  
V9E 1C9

(the "District")

OF THE FIRST PART

AND:

(the "Owner")

OF THE SECOND PART

WHEREAS:

A. The Owner is the registered owner of, and proposes to subdivide land located within the District of Highlands and described as:

(insert legal description of the "Lands");

B. In order to subdivide the Lands in conformity with the proposed subdivision plan attached as Schedule "A" to the agreement, the Owner is required to construct and install certain works and services as described in Schedule "B" (the "secured services") within or in the vicinity of the Lands;

Form F-12

- C. This Owner has requested approval of the subdivision of the Lands prior to construction and installation of the secured services and the District has agreed to accept security for completion of the secured services in accordance with this agreement.

NOW THEREFORE pursuant to Section 940 of the Local Government Act and in consideration of the terms of this agreement and the sum of \$10.00 now paid by each party to the other, the District and the Owner agree as follows:

1. The estimated cost of completing the secured services, including construction costs, engineering fees, administrative costs and contingency allowances, is \$ \_\_\_\_\_.
2. The Owner has paid the amount of \$ \_\_\_\_\_(the "Security") to the District prior to execution of this agreement as security for the installation and construction of the secured services.
3. If the secured services have not been completed within one year from the date of this agreement, the Security shall be forfeited to the District for its use in accordance with the terms of this agreement.
4. If the secured services are not completed upon the expiry of one year from the date of this agreement:
  - (a) The District shall retain the Security and shall use the Security only for completion of the secured services. Without limitation, the District may employ the Security towards the design and construction of the secured services and other facilities necessary for development of the secured services.
  - (b) The District may invest the Security in its discretion and any interest on the Security shall be retained by the District and applied towards completion of the secured services.
  - (c) The District shall have discretion as to the timing and method of the completion of the secured services.
  - (d) The District shall have no obligation to the Owner to complete the secured services within any definite period and under no circumstances shall the Security or interest on the security be repaid to the Owner.
  - (e) For so long as the Owner owns the Lands, the Owner shall permit the District to enter and make use of the Lands without payment or compensation, as may be necessary or convenient for the completion of the secured services by the District.

Form F-12

- 5. Following forfeiture of the security, the Owner shall have no further obligation to the District in respect of completion of the secured services, other than as set out in Section 4(e).
- 6. The Owner shall not represent to any person that the District is obligated to complete the secured services within any defined period.
- 7. If the secured services are completed within one year of the date of this agreement, the Security shall be returned to the owner, without interest.
- 8. If the secured services are partially completed upon the expiry of one year from the date of this agreement, the District may retain a portion of the Security equivalent to the proportion of the secured services not completed, as estimated by the Approving Officer, and the terms of this agreement apply to the retained portion.

EXECUTED on behalf of the District and the Owner this \_\_\_\_ day of \_\_\_\_\_, 20 .

THE CORPORATE SEAL of the )  
DISTRICT OF HIGHLANDS was )  
hereunto affixed in the presence of: )

c/s

\_\_\_\_\_ )

\_\_\_\_\_ )

SIGNED, SEALED AND DELIVERED )  
in the presence of: )

\_\_\_\_\_ )  
WITNESS )

OWNER

\_\_\_\_\_ )  
ADDRESS )

\_\_\_\_\_ )  
OCCUPATION )

SCHEDULE "E" OF THE SUBDIVISION OR  
DEVELOPMENT OF LAND BYLAW

BARE LAND STRATA SERVICE LEVELS  
FOR FEWER THAN FOUR LOTS

CONSOLIDATED

SCHEDULE "E"- BARE LAND STRATA SERVICE LEVELS  
( FOR FEWER THAN FOUR LOTS )

Roads, storm water (drains), water service, sanitary sewerage, electrical/wiring, and walkways/trails shall be provided to Service Level 1 as per Schedule "B"; except that roads shall be constructed with a minimum asphalt paved width of 5.4 m and a maximum grade of 15 %.

CONSOLIDATED

SCHEDULE "F" OF THE SUBDIVISION OR  
DEVELOPMENT OF LAND BYLAW

BUILDING PERMIT SERVICE LEVELS

CONSOLIDATED

## SCHEDULE "F"- ONSITE BUILDING PERMIT SERVICE LEVELS

Roads, storm water (drains), water service, sanitary sewerage, and electrical/wiring shall be provided to Service Level 1 as per Schedule "B"; except that roads shall be constructed with a minimum asphalt paved width of 5.4 m and a maximum grade of 15%.

CONSOLIDATED